



THINGWELL ELECTRONICS

TEL:+86-755-27435731 FAX:+86-755-27132381

<http://www.lcdmaker.com>

File Name	Specification For TINK 1.5" EPD	Module Number	TINK-EPD154A45
Version	A/1	Page Number	1 of 33

Specification For TINK 1.5"EPD

Model NO.: TINK-EPD154A45

Product VER:A0

Customer Approval

Customer	
Approval By	
Date Of Approval	

It will be agreed by the receiver,if not sign back the Specification within 15days.

Prepared By	Checked By	Approval By
Wang lin	Xiao zhongwu Zhou yufeng Huang youfa	Hu ziping



THINGWELL ELECTRONICS

TEL:+86-755-27435731 FAX:+86-755-27132381

<http://www.lcdmaker.com>

File Name	Specification For TINK 1.5' EPD	Module Number	TINK-EPD154A45
Version	A/1	Page Number	2 of 33

Version	Content	Date	Producer
A0	New release	2019/4/4	Wang lin



File Name	Specification For TINK 1.5" EPD	Module Number	TINK-EPD154A45
Version	A/1	Page Number	3 of 33

CONTENTS

1	General Description	4
2	Features	4
3	Application	4
4	Mechanical Specification	4
5	Mechanical Drawing of EPD Module	5
6	Input/Output Terminals	6
7	MCU Interface.....	7
7.1	MCU Interface Selection	7
7.2	MCU Serial Peripheral Interface (4-wire SPI)	7
7.3	MCU Serial Peripheral Interface (3-wire SPI)	9
8	Temperature sensor operation.....	11
9	COMMAND TABLE.....	12
10	Reference Circuit.....	17
11	Absolute Maximum Rating	19
12	DC Characteristics.....	19
13	Serial Peripheral Interface Timing.....	20
14	Power Consumption.....	20
15	Typical Operating Sequence.....	21
15.1	Normal Operation Flow	21
15.2	Reference program code	22
16	Optical Characteristics.....	23
16.1	Specifications	23
16.2	Definition Of Contrast Ratio	24
16.3	Reflection Ratio.....	24
17	Handing Safety And Environment Requirements.....	25
18	Reliability Test.....	27
19	Block Diagram.....	28
20	PartA/PartB specification.....	28
21	Point And Line Standard.....	29
22	Barcode.....	31
23	Packing.....	32



File Name	Specification For TINK 1.5" EPD	Module Number	TINK-EPD154A45
Version	A/1	Page Number	4 of 33

1. General Description

TINK-EPD154A45 is an Active Matrix Electrophoretic Display (AMEPD), with interface and a reference system design. The 1.5" active area contains 200×200 pixels, and has 1-bit B/W full display capabilities. An integrated circuit contains gate buffer, source buffer, interface, timing control logic, oscillator, DC-DC. SRAM.LUT, VCOM and border are supplied with each panel.

2. Features

- 200×200 pixels display
- High contrast
- High reflectance
- Ultra wide viewing angle
- Ultra low power consumption
- Pure reflective mode
- Bi-stable display
- Commercial temperature range
- Landscape, portrait modes
- Hard-coat antiglare display surface
- Ultra Low current deep sleep mode
- On chip display RAM
- Low voltage detect for supply voltage
- High voltage ready detect for driving voltage
- Internal temperature sensor
- 10-byte OTP space for module identification
- Waveform stored in On-chip OTP
- Serial peripheral interface available
- On-chip oscillator
- On-chip booster and regulator control for generating VCOM, Gate and Source driving voltage
- I2C signal master interface to read external temperature sensor/built-in temperature sensor

3. Application

Electronic Shelf Label System

4. Mechanical Specifications

Parameter	Specifications	Unit	Remark
Screen Size	1.5	Inch	
Display Resolution	200(H)×200(V)	Pixel	Dpi:188
Active Area	27.00 (H)×27.00 (V)	mm	
Pixel Pitch	0.135×0.135	mm	
Pixel Configuration	Square		
Outline Dimension	37.32(H)×31.80(V) ×1.05(D)	mm	
Weight	2.1±0.2	g	

File Name	Specification For TINK 1.5" EPD	Module Number	TINK-EPD154A45
Version	A/1	Page Number	5 of 33

5. Mechanical Drawing of EPD module

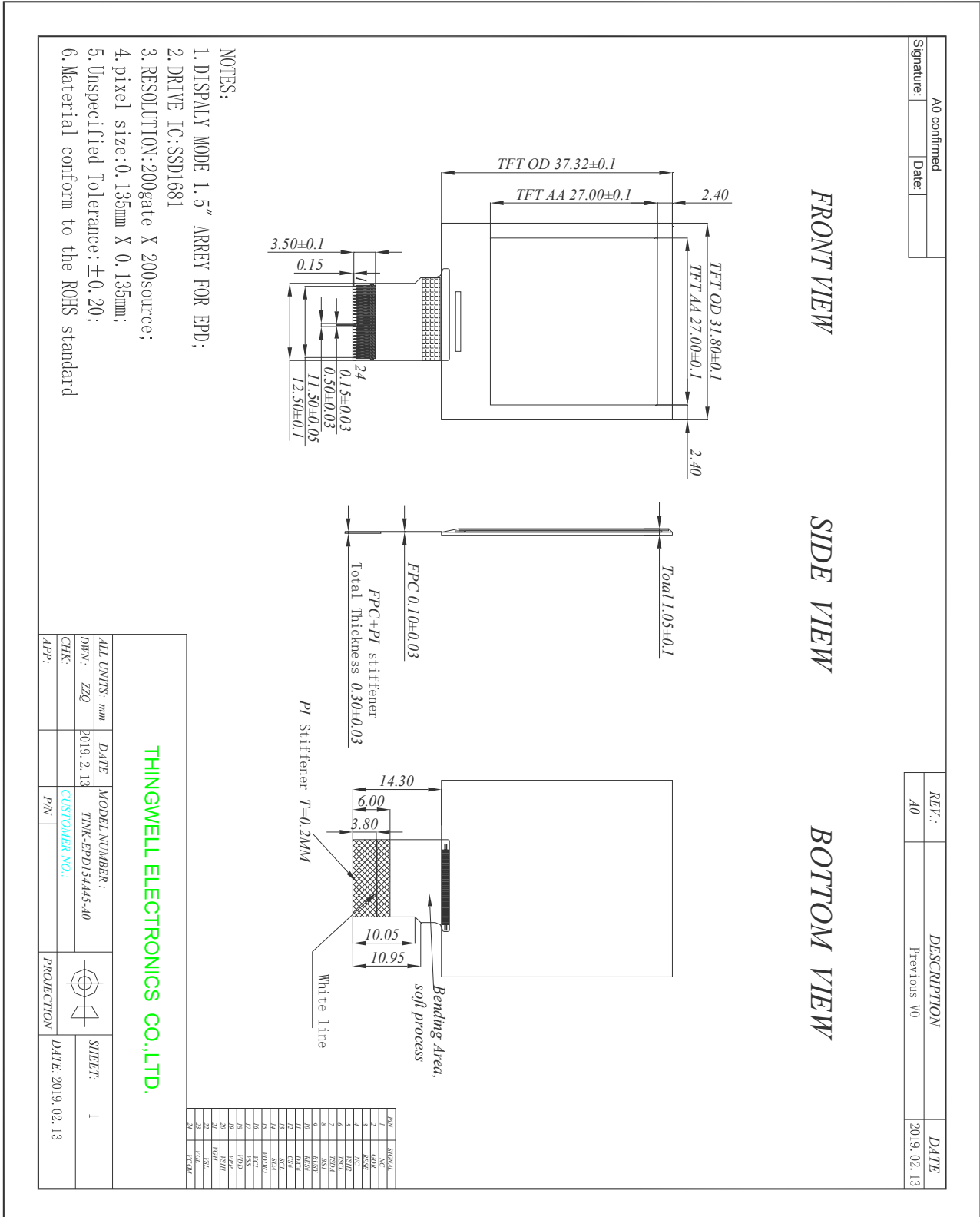

File Name	Specification For TINK 1.5" EPD	Module Number	TINK-EPD154A45
Version	A/1	Page Number	6 of 33

6. Input/Output Terminals

Pin #	Single	Description	Remark
1	NC	No connection and do not connect with other NC pins	Keep Open
2	GDR	N-Channel MOSFET Gate Drive Control	
3	RESE	Current Sense Input for the Control Loop	
4	NC	No connection and do not connect with other NC pins e	Keep Open
5	VSH2	This pin is Positive Source driving voltage	
6	TSCL	I2C Interface to digital temperature sensor Clock pin	
7	TSDA	I2C Interface to digital temperature sensor Date pin	
8	BS1	Bus selection pin	Note 6-5
9	BUSY	Busy state output pin	Note 6-4
10	RES #	Reset	Note 6-3
11	D/C #	Data /Command control pin	Note 6-2
12	CS #	Chip Select input pin	Note 6-1
13	SCL	serial clock pin (SPI)	
14	SDA	serial data pin (SPI)	
15	VDDIO	Power for interface logic pins	
16	VCI	Power Supply pin for the chip	
17	VSS	Ground	
18	VDD	Core logic power pin	
19	VPP	Power Supply for OTP Programming	
20	VSH1	This pin is Positive Source driving voltage	
21	VGH	This pin is Positive Gate driving voltage	
22	VSL	This pin is Negative Source driving voltage	
23	VGL	This pin is Negative Gate driving voltage	
24	VCOM	These pins are VCOM driving voltage	

File Name	Specification For TINK 1.5" EPD	Module Number	TINK-EPD154A45
Version	A/1	Page Number	7 of 33

Note 6-1: This pin (CS#) is the chip select input connecting to the MCU. The chip is enabled for MCU communication: only when CS# is pulled LOW.

Note 6-2: This pin (D/C#) is Data/Command control pin connecting to the MCU. When the pin is pulled HIGH, the data will be interpreted as data. When the pin is pulled LOW, the data will be interpreted as command.

Note 6-3: This pin (RES#) is reset signal input. The Reset is active low.

Note 6-4: This pin (BUSY) is Busy state output pin. When Busy is High the operation of chip should not be interrupted and any commands should not be issued to the module. The driver IC will put Busy pin High when the driver IC is working such as:

- Outputting display waveform; or
- Communicating with digital temperature sensor

Note 6-5: This pin (BS1) is for 3-line SPI or 4-line SPI selection. When it is “Low”, 4-line SPI is selected. When it is “High”, 3-line SPI (9 bits SPI) is selected.

7. MCU Interface

7.1 MCU interface selection

The TINK-EPD154A45 can support 3-wire/4-wire serial peripheral interface. In the Module, the MCU interface is pin selectable by BS1 pins shown in.

Table 7-1: MCU interface selection

BS1	MPU Interface
L	4-lines serial peripheral interface (SPI)
H	3-lines serial peripheral interface (SPI) - 9 bits SPI

7.2 MCU Serial Peripheral Interface (4-wire SPI)

The 4-wire SPI consists of serial clock SCL, serial data SDA, D/C# and CS#, The control pins status in 4-wire SPI in writing command/data is shown in Table 7-2 and the write procedure 4-wire SPI is shown in Figure 7-2.

Table 7-2 : Control pins status of 4-wire SPI

Function	SCL pin	SDA pin	D/C# pin	CS# pin
Write command	↑	Command bit	L	L
Write data	↑	Data bit	H	L

Note:

- (1) L is connected to V_{SS} and H is connected to V_{DDIO}
- (2) ↑ stands for rising edge of signal

File Name	Specification For TINK 1.5" EPD	Module Number	TINK-EPD154A45
Version	A/1	Page Number	8 of 33

In the write mode, SDA is shifted into an 8-bit shift register on each rising edge of SCL in the order of D7, D6, ... D0. The level of D/C# should be kept over the whole byte. The data byte in the shift register is written to the Graphic Display Data RAM (RAM)/Data Byte register or command Byte register according to D/C# pin.

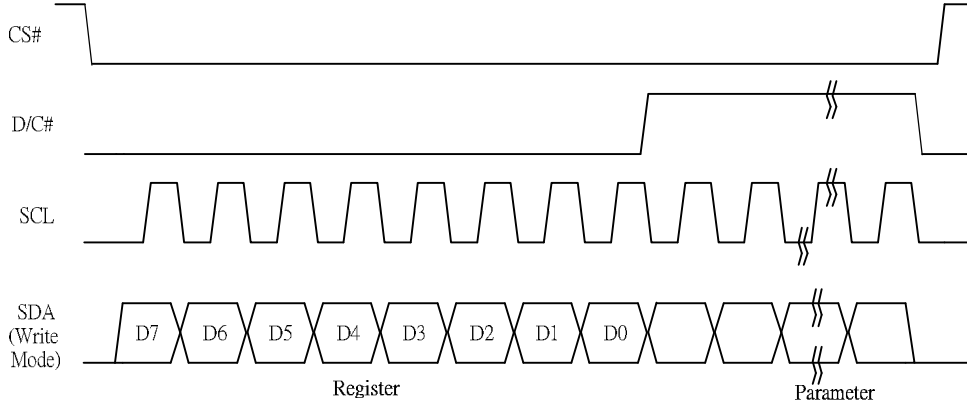

Figure 7-2: Write procedure in 4-wire SPI mode

In the Read mode:

1. After driving CS# to low, MCU need to define the register to be read.
2. SDA is shifted into an 8-bit shift register on each rising edge of SCL in the order of D7, D6, ... D0 with D/C# keep low.
3. After SCL change to low for the last bit of register, D/C# need to drive to high.
4. SDA is shifted out an 8-bit data on each falling edge of SCL in the order of D7, D6, ... D0.
5. Depending on register type, more than 1 byte can be read out. After all byte are read, CS# need to drive to high to stop the read operation.

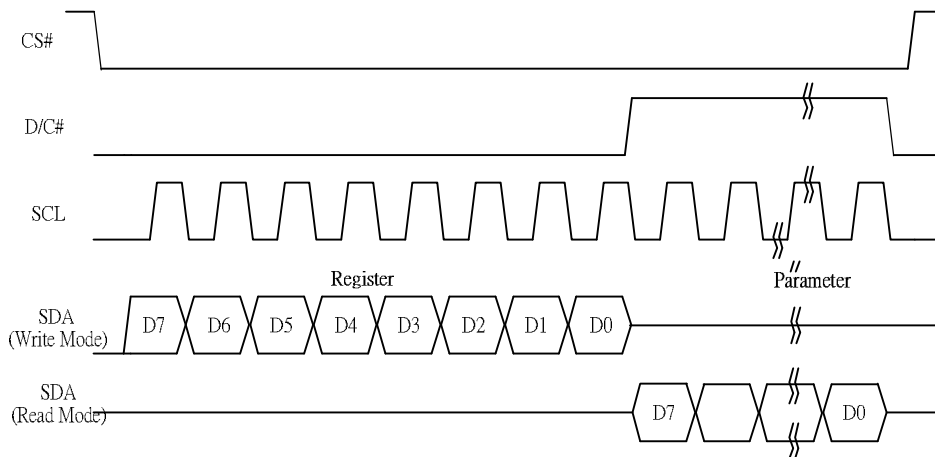

Figure 7-2: Read procedure in 4-wire SPI mode

File Name	Specification For TINK 1.5" EPD	Module Number	TINK-EPD154A45
Version	A/1	Page Number	9 of 33

7.3 MCU Serial Peripheral Interface (3-wire SPI)

The 3-wire SPI consists of serial clock SCL, serial data SDA and CS#. The operation is similar to 4-wire SPI while D/C# pin is not used and it must be tied to LOW. The control pins status in 3-wire SPI is shown in Table 7-3.

Table 7-3 : Control pins status of 3-wire SPI

Function	SCL pin	SDA pin	D/C# pin	CS# pin
Write command	↑	Command bit	Tie LOW	L
Write data	↑	Data bit	Tie LOW	L

Note:

- (1)L is connected to V_{SS} and H is connected to V_{DDIO}
- (2)↑ stands for rising edge of signal

In the write operation, a 9-bit data will be shifted into the shift register on each clock rising edge. The bit shifting sequence is D/C# bit, D7 bit, D6 bit to D0 bit. The first bit is D/C# bit which determines the following byte is command or data. When D/C# bit is 0, the following byte is command. When D/C# bit is 1, the following byte is data. shows the write procedure in 3-wire SPI

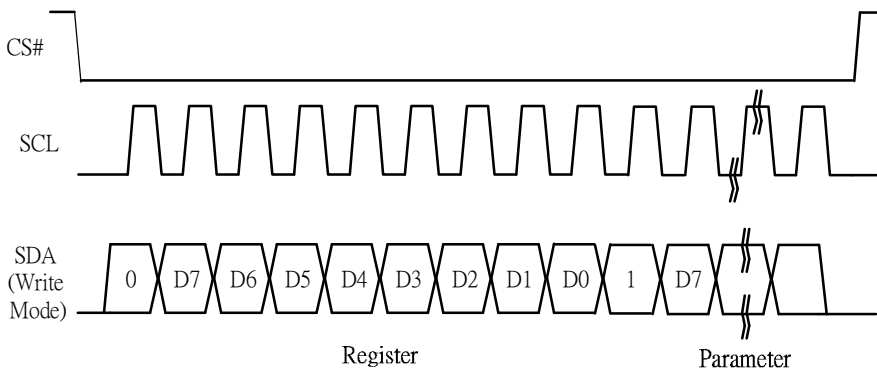

Figure 7-3: Write procedure in 3-wire SPI mode

File Name	Specification For TINK 1.5" EPD	Module Number	TINK-EPD154A45
Version	A/1	Page Number	10 of 33

In the Read mode:

1. After driving CS# to low, MCU need to define the register to be read.
2. D/C#=0 is shifted thru SDA with one rising edge of SCL
3. SDA is shifted into an 8-bit shift register on each rising edge of SCL in the order of D7, D6, ... D0.
4. D/C#=1 is shifted thru SDA with one rising edge of SCL
5. SDA is shifted out an 8-bit data on each falling edge of SCL in the order of D7, D6, ... D0.
6. Depending on register type, more than 1 byte can be read out. After all byte are read, CS# need to drive to high to stop the read operation.

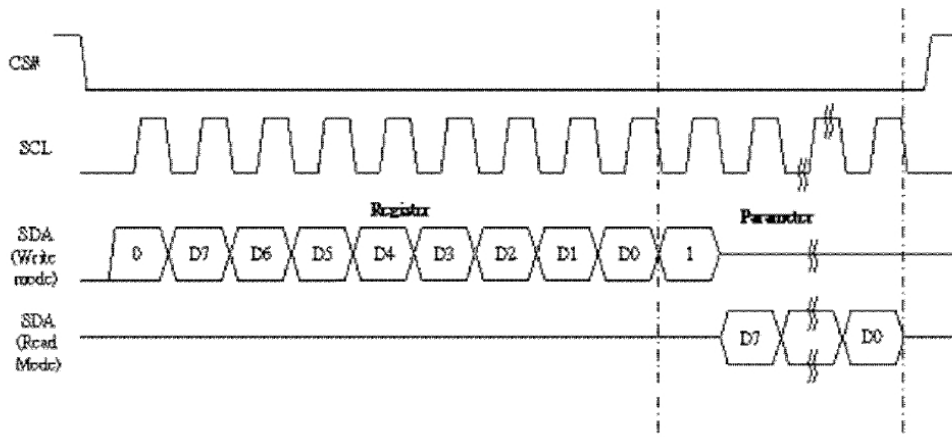

Figure 7-3: Read procedure in 3-wire SPI mode



File Name	Specification For TINK 1.5" EPD	Module Number	TINK-EPD154A45
Version	A/1	Page Number	11 of 33

8. Temperature sensor operation

Following is the way of how to sense the ambient temperature of the module. First, use an external temperature sensor to get the temperature value and converted it into HEX format with below mapping table, then send command 0x1A with the HEX temperature value to the module thru the SPI interface.

The temperature value to HEX conversion is as follow:

1. If the Temperature value MSByte bit D11 = 0, then

The temperature is positive and value (DegC) = + (Temperature value) / 16

2. If the Temperature value MSByte bit D11 = 1, then

The temperature is negative and value (DegC) = ~ (2's complement of Temperature value) / 16

12-bit binary (2's complement)	Hexadecimal Value	Decimal Value	Value [DegC]
0111 1111 0000	7F0	2032	127
0111 1110 1110	7EE	2030	126.875
0111 1110 0010	7E2	2018	126.125
0111 1101 0000	7D0	2000	125
0001 1001 0000	190	400	25
0000 0000 0010	002	2	0.125
0000 0000 0000	000	0	0
1111 1111 1110	FFE	-2	-0.125
1110 0111 0000	E70	-400	-25
1100 1001 0010	C92	-878	-54.875
1100 1001 0000	C90	-880	-55



File Name	Specification For TINK 1.5" EPD	Module Number	TINK-EPD154A45
Version	A/1	Page Number	12 of 33

9. COMMAND TABLE

R/W#	D/C#	Hex	D7	D6	D5	D4	D3	D2	D1	D0	Command	Description						
0	0	01	0	0	0	0	0	0	0	1	Driver Output control	Gate setting A[8:0]= C7h [POR], 200 MUX MUX Gate lines setting as (A[8:0] + 1). B[2:0] = 000 [POR]. Gate scanning sequence and direction B[2]: GD Selects the 1st output Gate GD=0 [POR], G0 is the 1st gate output channel, gate output sequence is G0,G1, G2, G3, ... GD=1, G1 is the 1st gate output channel, gate output sequence is G1, G0, G3, G2, ... B[1]: SM Change scanning order of gate driver. SM=0 [POR], G0, G1, G2, G3...G199 SM=1, G0, G2, G4 ...G198, G1, G3, ...G199 B[0]: TB TB = 0 [POR], scan from G0 to G199 TB = 1, scan from G199 to G0.						
0	1		A7	A6	A5	A4	A3	A2	A1	A0								
0	0		0	0	0	0	0	0	0	A8								
0	0		0	0	0	0	0	B2	B1	B0								
0	0	03	0	0	0	0	0	0	1	1	Gate Driving voltage Control	Set Gate driving voltage A[4:0] = 00h [POR] VGH setting for 20V = 00h [POR] and 17h						
0	1		0	0	0	A4	A3	A2	A1	A0								
0	0	04	0	0	0	0	0	1	0	0	Source Driving voltage Control	Set Source driving voltage A[7:0] = 41h [POR], VSH1 at 15V B[7:0] = A8h [POR], VSH2 at 5V. C[7:0] = 32h [POR], VSL at -15V Remark: VSH1 >= VSH2						
0	1		A7	A6	A5	A4	A3	A2	A1	A0								
0	1		B7	B6	B5	B4	B3	B2	B1	B0								
0	1		C7	C6	C5	C4	C3	C2	C1	C0								
0	0	10	0	0	0	1	0	0	0	0	Deep Sleep mode	Deep Sleep mode Control: <table border="1"> <tr> <th>A[1:0] :</th> <th>Description</th> </tr> <tr> <td>00</td> <td>Normal Mode [POR]</td> </tr> <tr> <td>01</td> <td>Enter Deep Sleep Mode 1</td> </tr> </table> After this command initiated, the chip will enter Deep Sleep Mode, BUSY pad will keep output high. Remark: To Exit Deep Sleep mode, User required to send HWRESET to the driver	A[1:0] :	Description	00	Normal Mode [POR]	01	Enter Deep Sleep Mode 1
A[1:0] :	Description																	
00	Normal Mode [POR]																	
01	Enter Deep Sleep Mode 1																	
0	1		0	0	0	0	0	0	A1	A0								
0	0	11	0	0	0	1	0	0	0	1	Data Entry mode setting	Define data entry sequence A[2:0] = 011 [POR] A [1:0] = ID[1:0] Address automatic increment / decrement setting The setting of incrementing or decrementing of the address counter can be made independently in each upper and lower bit of the address. 00 –Y decrement, X decrement, 01 –Y decrement, X increment, 10 –Y increment, X decrement, 11 –Y increment, X increment [POR] A[2] = AM Set the direction in which the address counter is updated automatically after data are written to the RAM. AM= 0, the address counter is updated in the X direction. [POR] AM = 1, the address counter is updated in the Y direction.						
0	1		0	0	0	0	0	A2	A1	A0								
R/W#	D/C#	Hex	D7	D6	D5	D4	D3	D2	D1	D0	Command	Description						



THINGWELL ELECTRONICS

TEL:+86-755-27435731 FAX:+86-755-27132381

http://www.lcdmaker.com

File Name	Specification For TINK 1.5'' EPD	Module Number	TINK-EPD154A45
Version	A/1	Page Number	13 of 33

0	0	12	0	0	0	1	0	0	1	0	SW RESET	It resets the commands and parameters to their S/W Reset default values except R10h-Deep Sleep Mode During operation, BUSY pad will output high. Note: RAM are unaffected by this command.																						
0	0	20	0	0	1	0	0	0	0	0	Master Activation	Activate Display Update Sequence The Display Update Sequence Option is located at R22h. BUSY pad will output high during operation. User should not interrupt this operation to avoid corruption of panel images.																						
0	0	21	0	0	1	1	0	0	0	1	Display Update Control 1	RAM content option for Display Update A[7:0] = 00h [POR] B[7:0] = 00h [POR] A[7:4] Red RAM option <table border="1"> <tr><td>0000</td><td>Normal</td></tr> <tr><td>0100</td><td>Bypass RAM content as 0</td></tr> <tr><td>1000</td><td>Inverse RAM content</td></tr> </table> A[3:0] BW RAM option <table border="1"> <tr><td>0000</td><td>Normal</td></tr> <tr><td>0100</td><td>Bypass RAM content as 0</td></tr> <tr><td>1000</td><td>Inverse RAM content</td></tr> </table>	0000	Normal	0100	Bypass RAM content as 0	1000	Inverse RAM content	0000	Normal	0100	Bypass RAM content as 0	1000	Inverse RAM content										
0000	Normal																																	
0100	Bypass RAM content as 0																																	
1000	Inverse RAM content																																	
0000	Normal																																	
0100	Bypass RAM content as 0																																	
1000	Inverse RAM content																																	
0	1		A7	A6	A5	A4	A3	A2	A1	A0																								
0	1		B7	0	0	0	0	0	0	0																								
0	0	22	0	0	1	0	0	0	1	0	Display Update Control 2	Display Update Sequence Option: Enable the stage for Master Activation A[7:0]= FFh (POR) <table border="1"> <thead> <tr> <th>Operating sequence</th> <th>Parameter (in Hex)</th> </tr> </thead> <tbody> <tr><td>Enable clock signal</td><td>80</td></tr> <tr><td>Disable clock signal</td><td>01</td></tr> <tr><td>Enable clock signal → Enable Analog</td><td>C0</td></tr> <tr><td>Disable Analog → Disable clock signal</td><td>03</td></tr> <tr><td>Enable clock signal → Load LUT with DISPLAY Mode 1 → Disable clock signal</td><td>91</td></tr> <tr><td>Enable clock signal → Load LUT with DISPLAY Mode 2 → Disable clock signal</td><td>99</td></tr> <tr><td>Enable clock signal → Load temperature value → Load LUT with DISPLAY Mode 1 → Disable clock signal</td><td>B1</td></tr> <tr><td>Enable clock signal → Load temperature value → Load LUT with DISPLAY Mode 2 → Disable clock signal</td><td>B9</td></tr> <tr><td>Enable clock signal → Enable Analog → Display with DISPLAY Mode 1 → Disable Analog → Disable OSC</td><td>C7</td></tr> <tr><td>Enable clock signal → Enable Analog → Display with DISPLAY Mode 2 → Disable Analog → Disable OSC</td><td>CF</td></tr> </tbody> </table>	Operating sequence	Parameter (in Hex)	Enable clock signal	80	Disable clock signal	01	Enable clock signal → Enable Analog	C0	Disable Analog → Disable clock signal	03	Enable clock signal → Load LUT with DISPLAY Mode 1 → Disable clock signal	91	Enable clock signal → Load LUT with DISPLAY Mode 2 → Disable clock signal	99	Enable clock signal → Load temperature value → Load LUT with DISPLAY Mode 1 → Disable clock signal	B1	Enable clock signal → Load temperature value → Load LUT with DISPLAY Mode 2 → Disable clock signal	B9	Enable clock signal → Enable Analog → Display with DISPLAY Mode 1 → Disable Analog → Disable OSC	C7	Enable clock signal → Enable Analog → Display with DISPLAY Mode 2 → Disable Analog → Disable OSC	CF
Operating sequence	Parameter (in Hex)																																	
Enable clock signal	80																																	
Disable clock signal	01																																	
Enable clock signal → Enable Analog	C0																																	
Disable Analog → Disable clock signal	03																																	
Enable clock signal → Load LUT with DISPLAY Mode 1 → Disable clock signal	91																																	
Enable clock signal → Load LUT with DISPLAY Mode 2 → Disable clock signal	99																																	
Enable clock signal → Load temperature value → Load LUT with DISPLAY Mode 1 → Disable clock signal	B1																																	
Enable clock signal → Load temperature value → Load LUT with DISPLAY Mode 2 → Disable clock signal	B9																																	
Enable clock signal → Enable Analog → Display with DISPLAY Mode 1 → Disable Analog → Disable OSC	C7																																	
Enable clock signal → Enable Analog → Display with DISPLAY Mode 2 → Disable Analog → Disable OSC	CF																																	
0	1		A7	A6	A5	A4	A3	A2	A1	A0																								



THINGWELL ELECTRONICS

TEL:+86-755-27435731 FAX:+86-755-27132381

http://www.lcdmaker.com

File Name	Specification For TINK 1.5" EPD	Module Number	TINK-EPD154A45
Version	A/1	Page Number	14 of 33

														Enable clock signal →Enable Analog →Load temperature value →DISPLAY with DISPLAY Mode 1 →Disable Analog →Disable OSC	F7
														Enable clock signal →Enable Analog →Load temperature value →DISPLAY with DISPLAY Mode 2 →Disable Analog →Disable OSC	FF
0	0	24	0	0	1	0	0	1	0	0	Write RAM (Black White) / RAM 0x24	After this command, data entries will be written into the BW RAM until another command is written. Address pointers will advance accordingly For Write pixel: Content of Write RAM(BW) = 1 For Black pixel: Content of Write RAM(BW) = 0			
0	0	26	0	0	1	0	0	1	1	0	Write RAM (RED) / RAM 0x26	After this command, data entries will be written into the RED RAM until another command is written. Address pointers will advance accordingly. For Red pixel: Content of Write RAM(RED) = 1 For non-Red pixel [Black or White]: Content of Write RAM(RED) = 0			
0	0	28	0	0	1	0	1	0	0	0	VCOM Sense	Enter VCOM sensing conditions and hold for duration defined in 29h before reading VCOM value. The sensed VCOM voltage is stored in register The command required CLKEN=1 and ANALOGEN=1 Refer to Register 0x22 for detail. BUSY pad will output high during operation.			
0	0	29	0	0	1	0	1	0	0	1	VCOM Sense Duration	Stabling time between entering VCOM sensing mode and reading acquired. A[3:0] = 9h, duration = 10s. VCOM sense duration = (A[3:0]+1) sec			
0	1		0	1	0	0	A3	A2	A1	A0					
0	0	2A	0	0	1	0	1	0	1	1	Program VCOM OTP	Program VCOM register into OTP The command required CLKEN=1. Refer to Register 0x22 for detail. BUSY pad will output high during operation.			
0	0	2B	0	0	1	0	1	0	1	1	Write Register for VCOM Control	This command is used to reduce glitch when ACVCOM toggle. Two data bytes D04h and D63h should be set for this command.			
0	1		0	0	0	0	0	1	0	0					
0	1		0	1	1	0	0	0	1	1					
0	0	2c	0	0	1	0	1	1	0	0	Write VCOM register	Write VCOM register from MCU interface A[7:0] = 00h [POR]			
0	1		A7	A6	A5	A4	A3	A2	A1	A0					



THINGWELL ELECTRONICS

TEL:+86-755-27435731 FAX:+86-755-27132381

http://www.lcdmaker.com

File Name	Specification For TINK 1.5" EPD	Module Number	TINK-EPD154A45
Version	A/1	Page Number	15 of 33

R/W#	D/C#	Hex	D7	D6	D5	D4	D3	D2	D1	D0	Command	Description		
0	0	2D	0	0	1	0	1	1	0	1	OTP Register Read for Display Option	Read Register for Display Option: A[7:0]: VCOM OTP Selection (Command 0x37, Byte A) B[7:0]: VCOM Register (Command 0x2C) C[7:0]~G[7:0]: Display Mode (Command 0x37, Byte B to Byte F) [5 bytes] H[7:0]~K[7:0]: Waveform Version (Command 0x37, Byte G to Byte J) [4 bytes]		
1	1		A7	A6	A5	A4	A3	A2	A1	A0				
1	1		B7	B6	B5	B4	B3	B2	B1	B0				
1	1		C7	C6	C5	C4	C3	C2	C1	C0				
1	1		D7	D6	D5	D4	D3	D2	D1	D0				
1	1		E7	E6	E5	E4	E3	E2	E1	E0				
1	1		F7	F6	F5	F4	F3	F2	F1	F0				
1	1		G7	G6	G5	G4	G3	G2	G1	G0				
1	1		H7	H6	H5	H4	H3	H2	H1	H0				
1	1		I7	I6	I5	I4	I3	I2	I1	I0				
1	1		J7	J6	J5	J4	J3	J2	J1	J0				
1	1		K7	K6	K5	K4	K3	K2	K1	K0				
0	0	2E	0	0	1	0	1	1	1	0			User ID Read	Read 10 Byte User ID stored in OTP: A[7:0]~J[7:0]: UserID (R38, Byte A and Byte J) [10 bytes]
1	1		A7	A6	A5	A4	A3	A2	A1	A0				
1	1		B7	B6	B5	B4	B3	B2	B1	B0				
1	1		C7	C6	C5	C4	C3	C2	C1	C0				
1	1		D7	D6	D5	D4	D3	D2	D1	D0				
1	1		E7	E6	E5	E4	E3	E2	E1	E0				
1	1		F7	F6	F5	F4	F3	F2	F1	F0				
1	1		G7	G6	G5	G4	G3	G2	G1	G0				
1	1		H7	H6	H5	H4	H3	H2	H1	H0				
1	1		I7	I6	I5	I4	I3	I2	I1	I0				
1	1		J7	J6	J5	J4	J3	J2	J1	J0				
0	0	30	0	0	1	1	0	0	0	0	Program WS OTP	Program OTP of Waveform Setting The contents should be written into RAM before sending this command. The command required CLKEN=1. Refer to Register 0x22 for detail. BUSY pad will output high during operation.		
0	0	31	0	0	1	1	0	0	0	1	Load WS OTP	Load OTP of Waveform Setting The command required CLKEN=1. Refer to Register 0x22 for detail. BUSY pad will output high during operation.		
0	0	32	0	0	1	1	0	0	1	0	Write LUT register	Write LUT register from MCU interface [153 bytes], which contains the content of VS[nX-LUTm], TP[nX], RP[n], SR[nXY], FR[n] and XON[nXY] Refer to Session 6.7 WAVEFORM SETTING		
0	1		A7	A6	A5	A4	A3	A2	A1	A0				
0	1		B7	B6	B5	B4	B3	B2	B1	B0				
0	1		:	:	:	:	:	:	:	:				
0	1					
0	0	36	0	0	1	1	0	1	1	0	Program OTP selection	Program OTP Selection according to the OTP Selection Control [R37h and R38h] The command required CLKEN=1. Refer to Register 0x22 for detail. BUSY pad will output high during operation.		



THINGWELL ELECTRONICS

TEL:+86-755-27435731 FAX:+86-755-27132381

http://www.lcdmaker.com

File Name	Specification For TINK 1.5' EPD	Module Number	TINK-EPD154A45
Version	A/1	Page Number	16 of 33

R/W#	D/C#	Hex	D7	D6	D5	D4	D3	D2	D1	D0	Command	Description
0	0	38	0	0	1	1	1	0	0	0	Write Register for User ID	Write Register for User ID A[7:0]~J[7:0]: UserID [10 bytes] Remarks: A[7:0]~J[7:0] can be stored in OTP ID
0	1		A7	A6	A5	A4	A3	A2	A1	A0		
0	1		B7	B6	B5	B4	B3	B2	B1	B0		
0	1		C7	C6	C5	C4	C3	C2	C1	C0		
0	1		D7	D6	D5	D4	D3	D2	D1	D0		
0	1		E7	E6	E5	E4	E3	E2	E1	E0		
0	1		F7	F6	F5	F4	F3	F2	F1	F0		
0	1		G7	G6	G5	G4	G3	G2	G1	G0		
0	1		H7	H6	H5	H4	H3	H2	H1	H0		
0	1		I7	I6	I5	I4	I3	I2	I1	I0		
0	1		J7	J6	J5	J4	J3	J2	J1	J0		
0	0	39	0	0	1	1	1	0	0	1	OTP program mode	OTP program mode A[1:0] = 00: Normal Mode [POR] A[1:0] = 11: Internal generated OTP programming voltage Remark: User is required to EXACTLY follow the reference code sequences
0	1		0	0	0	0	0	0	A1	A0		
0	0	44	0	1	0	0	0	1	0	0	Set RAM X - address Start / End position	Specify the start/end positions of the window address in the X direction by an address unit for RAM A[5:0]: XSA[5:0], XStart, POR = 00h B[5:0]: XEA[5:0], XEnd, POR = 15h
0	1		0	0	A5	A4	A3	A2	A1	A0		
0	1		0	0	B5	B4	B3	B2	B1	B0		
0	0	45	0	1	0	0	0	1	0	1	Set Ram Y- address Start / End position	Specify the start/end positions of the window address in the Y direction by an address unit for RAM A[8:0]: YSA[8:0], YStart, POR = 000h B[8:0]: YEA[8:0], YEnd, POR = 127h
0	1		A7	A6	A5	A4	A3	A2	A1	A0		
0	1		0	0	0	0	0	0	0	A8		
0	1		B7	B6	B5	B4	B3	B2	B1	B0		
0	1		0	0	0	0	0	0	0	B8		
0	0	4E	0	1	0	0	1	1	1	0	Set RAM X address counter	Make initial settings for the RAM X address in the address counter (AC) A[5:0]: 00h [POR].
0	1		0	0	A5	A4	A3	A2	A1	A0		
0	0	4F	0	1	0	0	1	1	1	1	Set RAM Y address counter	Make initial settings for the RAM Y address in the address counter (AC) A[8:0]: 000h [POR].
0	1		A7	A6	A5	A4	A3	A2	A1	A0		
0	1		0	0	0	0	0	0	0	A8		

File Name	Specification For TINK 1.5" EPD	Module Number	TINK-EPD154A45
Version	A/1	Page Number	17 of 33

10.Reference Circuit

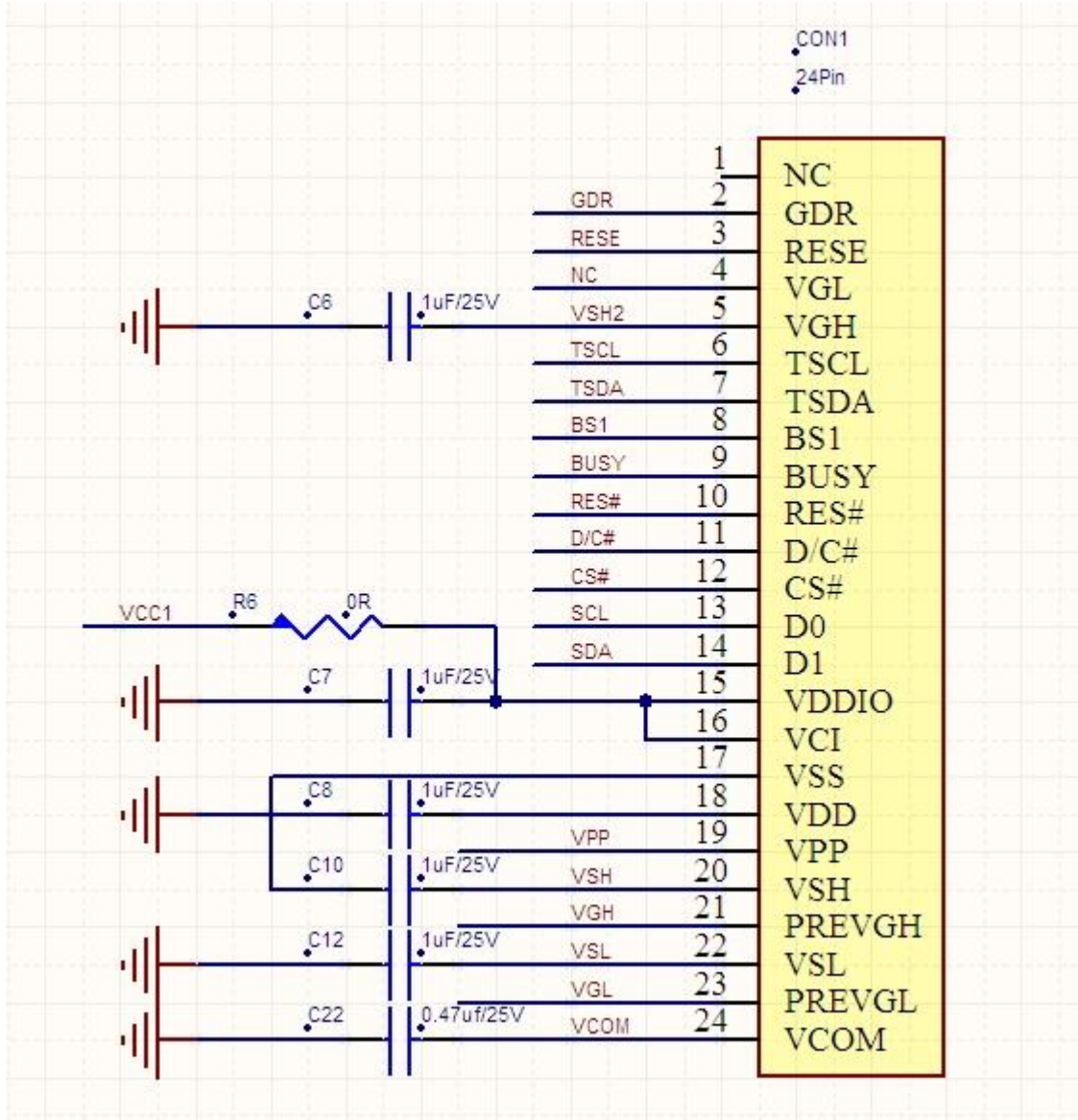

Figure. 10-1

File Name	Specification For TINK 1.5" EPD	Module Number	TINK-EPD154A45
Version	A/1	Page Number	18 of 33

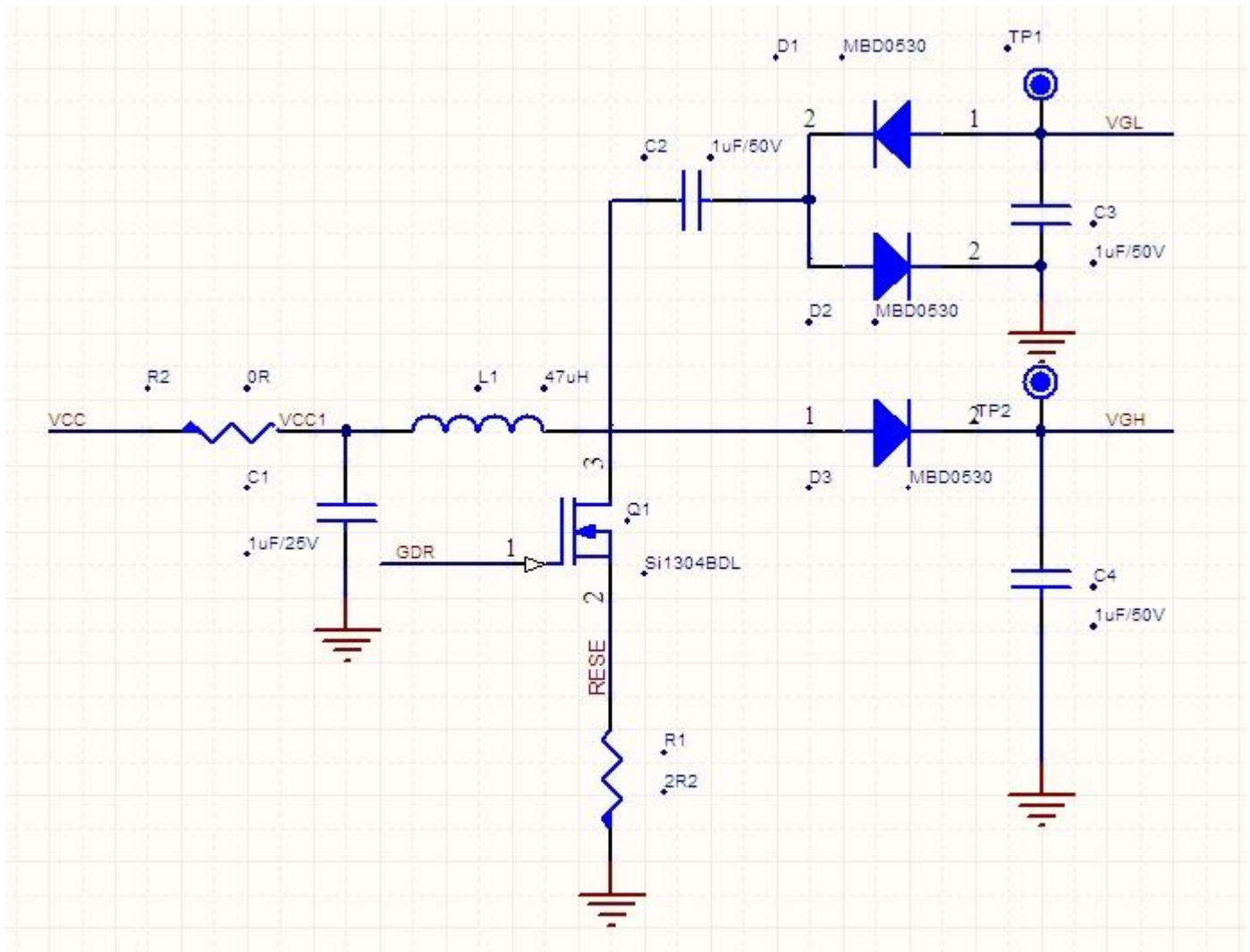

Figure. 10-2

Part Name	Value/Type	Reference Part
D4-D6	Diode	OnSemi:MBR0530
L2	47uH	Sumida:CDRH2D18/LDNP-470NC
Q1	NMOS	Vishay:Si1304BDL
R18	2.2Ohm	Vishay:CRCW08052R20FKEA
CON 24Pin	0.5mm ZIF socket	Hirose:FH34S-24S-0.5SH(50)

File Name	Specification For TINK 1.5'' EPD	Module Number	TINK-EPD154A45
Version	A/1	Page Number	19 of 33

11. ABSOLUTE MAXIMUM RATING

Table 11-1: Maximum Ratings

Symbol	Parameter	Rating	Unit
V _{CI}	Logic supply voltage	-0.5 to +4.0	V
T _{OPR}	Operation temperature range	0~50	°C
T _{STG}	Storage temperature range	-25~60	°C

Note;Maximum ratings are those values beyond which damages to the device may occur.

Functional operation should be restricted to the limits in the Electrical Characteristics chapter.

Note:The recommended operating temperature should be kept below 50°C

12.DC CHARACTERISTICS

The following specifications apply for: VSS=0V, VCI=3.3V, T_{OPR}=25°C.

Table 12-1: DC Characteristics

Symbol	Parameter	Test Condition	Applicable pin	Min.	Typ.	Max.	Unit
V _{CI}	VCI operation voltage	-	VCI	2.2	3.3	3.7	V
V _{IH}	High level input voltage	-	SDA, SCL, CS#, D/C#, RES#, BS1	0.8VDDIO	-	-	V
V _{IL}	Low level input voltage	-		-	-	0.2VDDIO	V
V _{OH}	High level output voltage	IOH = -100uA	BUSY,	0.9VDDIO	-	-	V
V _{OL}	Low level output voltage	IOL = 100uA		-	-	0.1VDDIO	V
I _{update}	Module operating current	-	-	-	1.5	-	mA
I _{sleep}	Deep sleep mode	VCI=3.3V	-	-	-	2	uA

The Typical power consumption is measured using associated 25°C waveform with following pattern transition: from horizontal scan pattern to vertical scan pattern. (Note 12-1)

- The listed electrical/optical characteristics are only guaranteed under the controller & waveform provided by XingTai.
- Vcom value will be OTP before in factory or present on the label sticker.

Note 12-1

The Typical power consumption

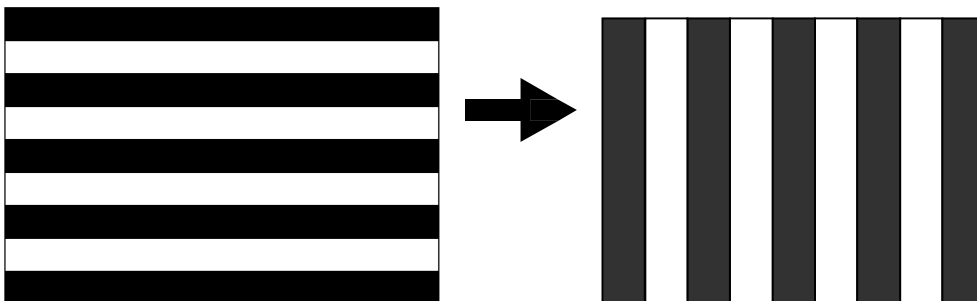

File Name	Specification For TINK 1.5" EPD	Module Number	TINK-EPD154A45
Version	A/1	Page Number	20 of 33

13. Serial Peripheral Interface Timing

The following specifications apply for: VSS=0V, VCI=2.2V to 3.7V, T_{OPR}=25°C

Write mode

Symbol	Parameter	Min	Typ	Max	Unit
fSCL	SCL frequency (Write Mode)			20	MHz
tCSSU	Time CS# has to be low before the first rising edge of SCLK	20			ns
tCSHLD	Time CS# has to remain low after the last falling edge of SCLK	20			ns
tCSHIGH	Time CS# has to remain high between two transfers	100			ns
tSCLHIGH	Part of the clock period where SCL has to remain high	25			ns
tSCLLOW	Part of the clock period where SCL has to remain low	25			ns
tSISU	Time SI (SDA Write Mode) has to be stable before the next rising edge of SCL	10			ns
tSIHLD	Time SI (SDA Write Mode) has to remain stable after the rising edge of SCL	40			ns

Read mode

Symbol	Parameter	Min	Typ	Max	Unit
fSCL	SCL frequency (Read Mode)			2.5	MHz
tCSSU	Time CS# has to be low before the first rising edge of SCLK	100			ns
tCSHLD	Time CS# has to remain low after the last falling edge of SCLK	50			ns
tCSHIGH	Time CS# has to remain high between two transfers	250			ns
tSCLHIGH	Part of the clock period where SCL has to remain high	180			ns
tSCLLOW	Part of the clock period where SCL has to remain low	180			ns
tSOSU	Time SO(SDA Read Mode) will be stable before the next rising edge of SCL		50		ns
tSOHLD	Time SO (SDA Read Mode) will remain stable after the falling edge of SCL		0		ns

Note: All timings are based on 20% to 80% of VDDIO-VSS

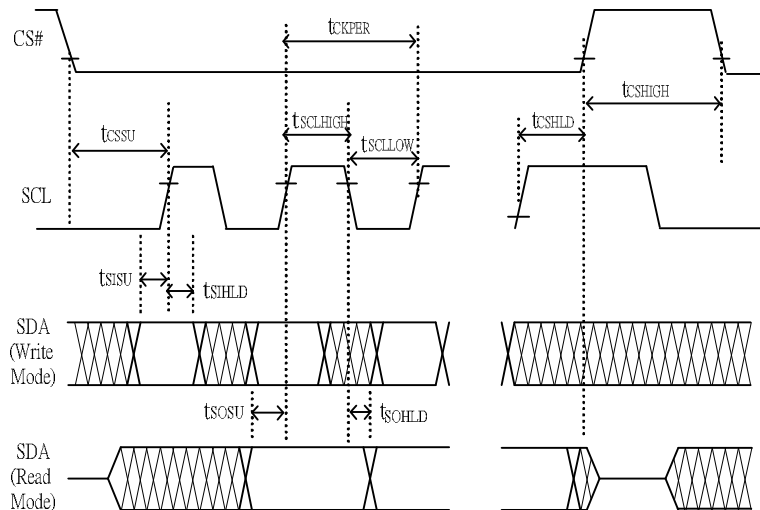

Figure 13-1 : Serial peripheral interface characteristics

14 .Power Consumption

Parameter	Symbol	Conditions	TYP	Max	Unit	Remark
Panel power consumption during update	-	25°C	-	8	mAs	-
Deep sleep mode	-	25°C	-	2	uA	-

File Name	Specification For TINK 1.5" EPD	Module Number	TINK-EPD154A45
Version	A/1	Page Number	21 of 33

mAs=update average current × update time

15. Typical Operating Sequence

15.1 Normal Operation Flow

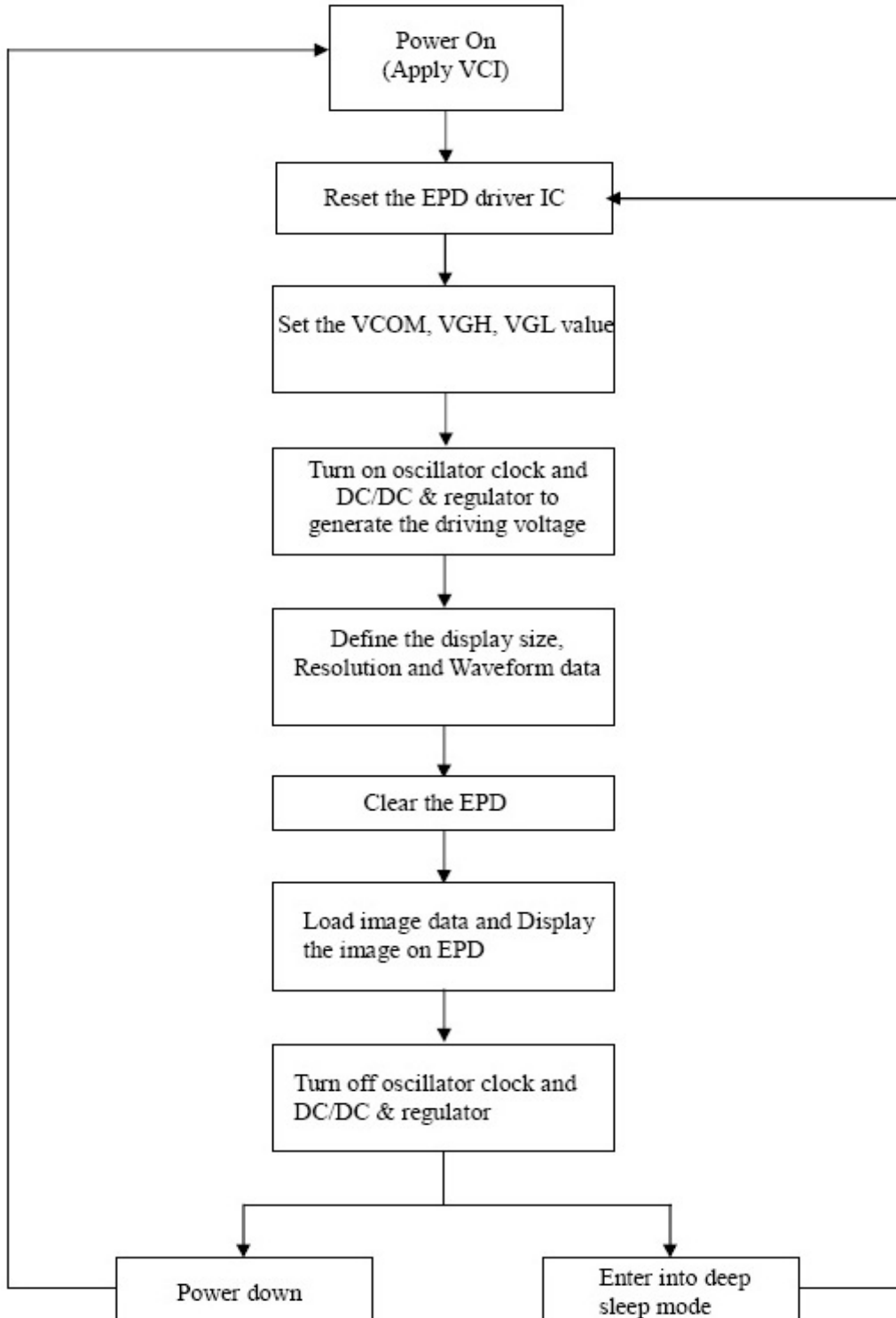

File Name	Specification For TINK 1.5" EPD	Module Number	TINK-EPD154A45
Version	A/1	Page Number	22 of 33

15.2 Reference Program Code

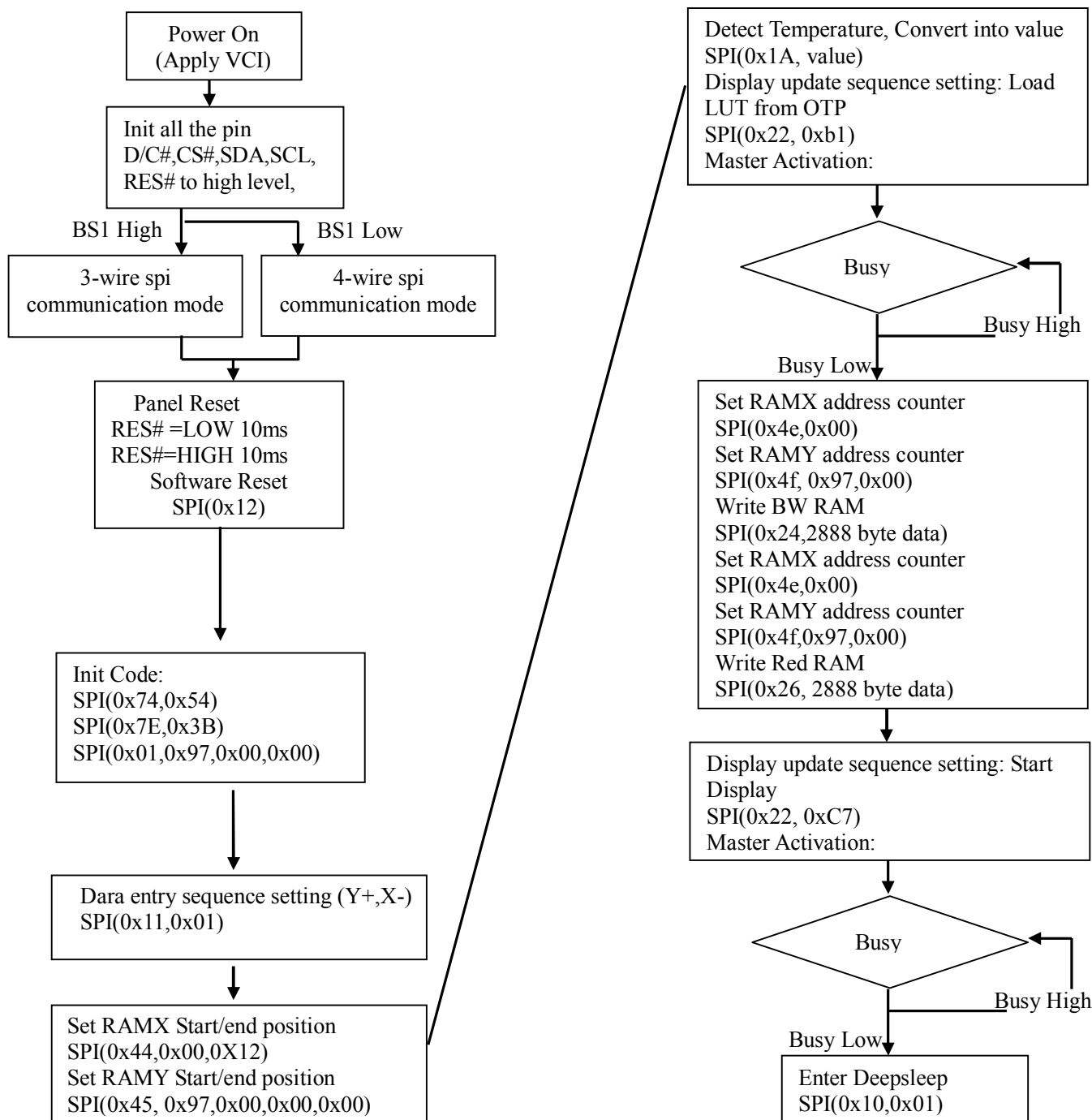



THINGWELL ELECTRONICS

TEL:+86-755-27435731 FAX:+86-755-27132381

<http://www.lcdmaker.com>

File Name	Specification For TINK 1.5" EPD	Module Number	TINK-EPD154A45
Version	A/1	Page Number	23 of 33

16. Optical characteristics

16.1 Specifications

Measurements are made with that the illumination is under an angle of 45 degrees, the detection is perpendicular unless otherwise specified.

T=25°C

SYMBOL	PARAMETER	CONDITIO NS	MIN	TYPE	MAX	UNIT	Note
R	Reflectance	White	30	35	-	%	Note 16-1
Gn	2Grey Level	-	-	DS+(WS-DS)×n(m-1)	-	L*	-
CR	Contrast Ratio	indoor	-	10	-	-	-
Panel's life	-	0°C~50°C		5years or 1000000 times	-	-	Note 16-2

M:2

WS : White state, DS : Dark state

Note 16-1 : Luminance meter : Eye - One Pro Spectrophotometer

File Name	Specification For TINK 1.5" EPD	Module Number	TINK-EPD154A45
Version	A/1	Page Number	24 of 33

16.2 Definition of contrast ratio

The contrast ratio (CR) is the ratio between the reflectance in a full white area (R1) and the reflectance in a dark area (Rd):

R1: white reflectance Rd: dark reflectance

$$CR = R1/Rd$$

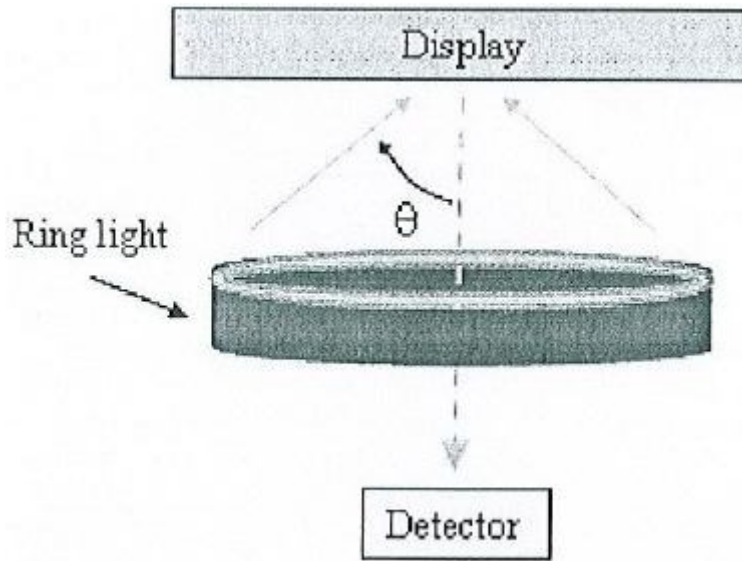

16.3 Reflection Ratio

The reflection ratio is expressed as :

$$R = \text{Reflectance Factor}_{\text{white board}} \times (L_{\text{center}} / L_{\text{white board}})$$

L_{center} is the luminance measured at center in a white area ($R=G=B=1$). $L_{\text{white board}}$ is the luminance of a standard white board. Both are measured with equivalent illumination source. The viewing angle shall be no more than 2 degrees.

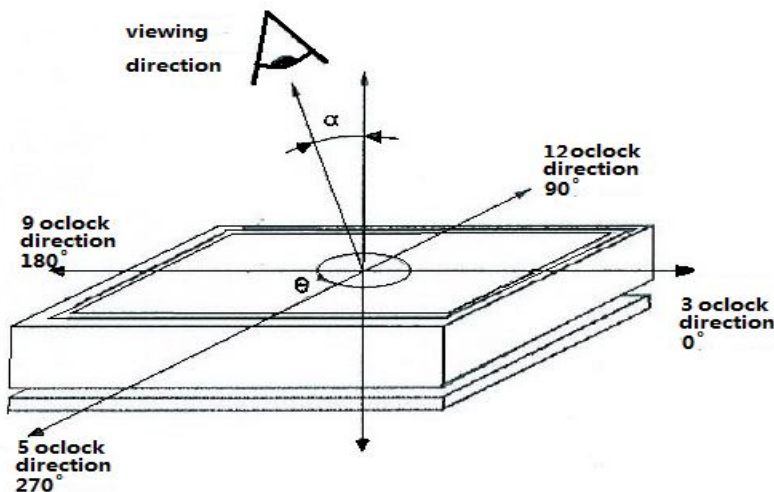



File Name	Specification For TINK 1.5" EPD	Module Number	TINK-EPD154A45
Version	A/1	Page Number	25 of 33

17. HANDLING, SAFETY AND ENVIRONMENTAL REQUIREMENTS

WARNING

The display glass may break when it is dropped or bumped on a hard surface. Handle with care. Should the display break, do not touch the electrophoretic material. In case of contact with electrophoretic material, wash with water and soap.

CAUTION

The display module should not be exposed to harmful gases, such as acid and alkali gases, which corrode electronic components.

Disassembling the display module can cause permanent damage and invalidate the warranty agreements.

IPA solvent can only be applied on active area and the back of a glass. For the rest part, it is not allowed.

Observe general precautions that are common to handling delicate electronic components. The glass can break and front surfaces can easily be damaged. Moreover the display is sensitive to static electricity and other rough environmental conditions.

Mounting Precautions

(1) It's recommended that you consider the mounting structure so that uneven force (ex. Twisted stress) is not applied to the module.

(2) It's recommended that you attach a transparent protective plate to the surface in order to protect the EPD. Transparent protective plate should have sufficient strength in order to resist external force.

(3) You should adopt radiation structure to satisfy the temperature specification.

(4) Acetic acid type and chlorine type materials for the cover case are not desirable because the former generates corrosive gas of attacking the PS at high temperature and the latter causes circuit break by electro-chemical reaction.

(5) Do not touch, push or rub the exposed PS with glass, tweezers or anything harder than HB pencil lead. And please do not rub with dust clothes with chemical treatment. Do not touch the surface of PS for bare hand or greasy cloth. (Some cosmetics deteriorate the PS)

(6) When the surface becomes dusty, please wipe gently with absorbent cotton or other soft materials like chamois soaks with petroleum benzene. Normal-hexane is recommended for cleaning the adhesives used to attach the PS. Do not use acetone, toluene and alcohol because they cause chemical damage to the PS.

(7) Wipe off saliva or water drops as soon as possible. Their long time contact with PS causes deformations and color fading.

Product specification	The data sheet contains final product specifications.
-----------------------	---



THINGWELL ELECTRONICS

TEL:+86-755-27435731 FAX:+86-755-27132381

<http://www.lcdmaker.com>

File Name	Specification For TINK 1.5" EPD	Module Number	TINK-EPD154A45
Version	A/1	Page Number	26 of 33

Limiting values

Limiting values given are in accordance with the Absolute Maximum Rating System (IEC 134). Stress above one or more of the limiting values may cause permanent damage to the device. These are stress ratings only and operation of the device at these or any other conditions above those given in the Characteristics sections of the specification is not implied. Exposure to limiting values for extended periods may affect device reliability.

Application information

Where application information is given, it is advisory and does not form part of the specification.

Product Environmental certification

ROHS

REMARK

All The specifications listed in this document are guaranteed for module only. Post-assembled operation or component(s) may impact module performance or cause unexpected effect or damage and therefore listed specifications is not warranted after any Post-assembled operation.



File Name	Specification For TINK 1.5" EPD	Module Number	TINK-EPD154A45
Version	A/1	Page Number	27 of 33

18. Reliability test

	TEST	CONDITION	METHOD	REMARK
1	High-Temperature Operation	T=40°C, RH=35%RH, For 240Hr	IEC 60 068-2-2Bb	
2	Low-Temperature Operation	T = 0°C for 240 hrs	IEC 60 068-2-2Ab	
3	High-Temperature Storage	T=60°C RH=35%RH For 240Hr Test in white pattern	IEC 60 068-2-2Bb	
4	Low-Temperature Storage	T = -25°C for 240 hrs Test in white pattern	IEC 60 068-2-2Ab	
5	High Temperature, High-Humidity Operation	T=40°C, RH=80%RH, For 168Hr	IEC 60 068-2-3CA	
6	High Temperature, High-Humidity Storage	T=50°C, RH=80%RH, For 240Hr Test in white pattern	IEC 60 068-2-3CA	
7	Temperature Cycle	-25°C(30min)~60°C(30min) , 50 Cycle Test in white pattern	IEC 60 068-2-14NB	
8	Package Vibration	1.04G, Frequency : 10~500Hz Direction : X, Y, Z Duration: 1 hours in each direction	Full packed for shipment	
9	Package Drop Impact	Drop from height of 122 cm on Concrete surface Drop sequence: 1 corner, 3 edges, 6 face One drop for each.	Full packed for shipment	
10	UV exposure Resistance	765 W/m ² for 168hrs, 40°C	IEC 60068-2-5 Sa	
11	Electrostatic discharge	Machine model: +/-250V, 0Ω, 200pF	IEC61000-4-2	

Actual EMC level to be measured on customer application.

Note1: The protective film must be removed before temperature test.

Note2: Stay white pattern for storage and non-operation test.

Note3: Operation is black/white/red pattern, hold time is 150S.

Note4: The function, appearance, opticals should meet the requirements of the test before and after the test.

Note5: Keep testing after 2 hours placing at 20°C-25°C.

File Name	Specification For TINK 1.5" EPD	Module Number	TINK-EPD154A45
Version	A/1	Page Number	28 of 33

19. Block Diagram

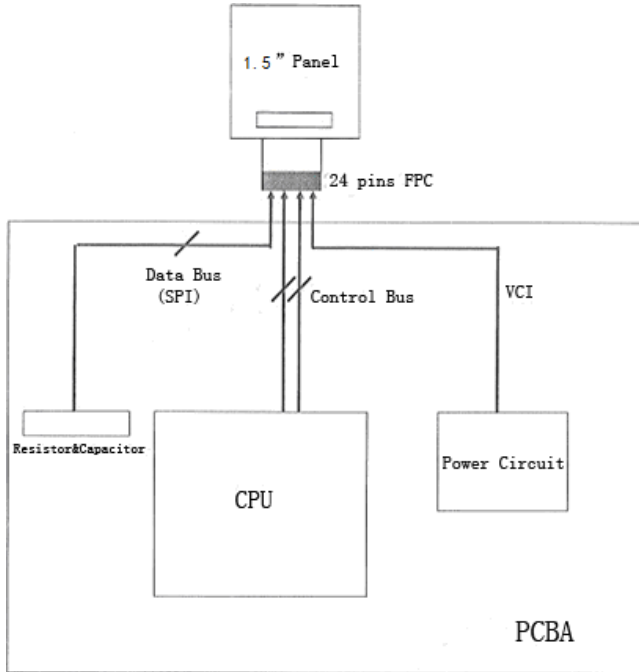

20. Part A/Part B specification

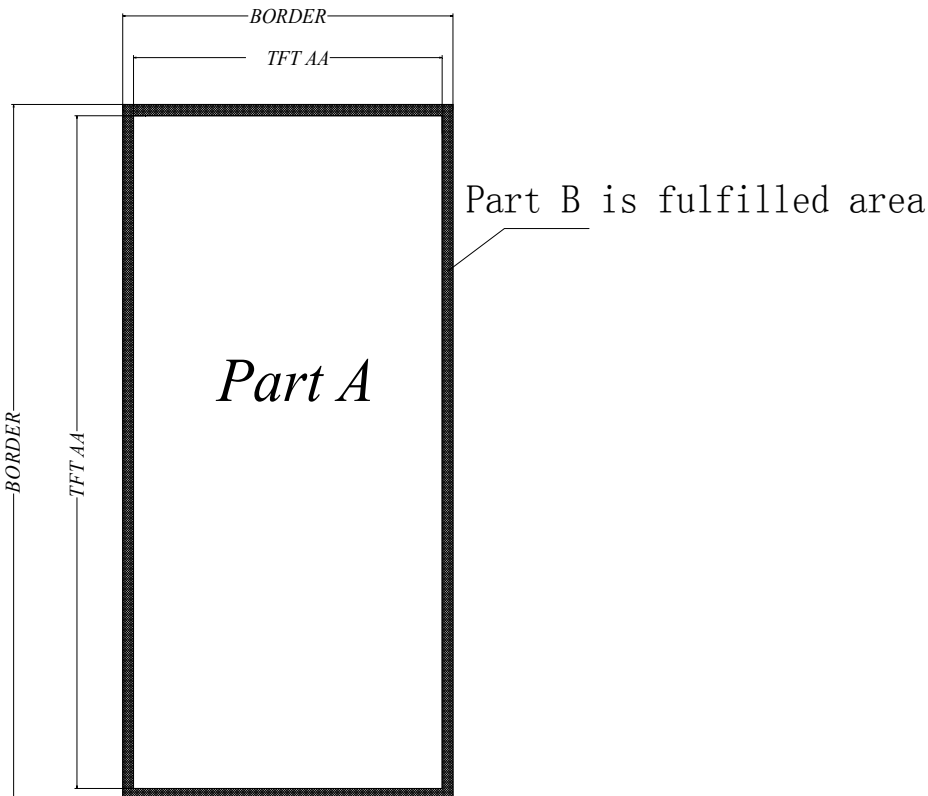

File Name	Specification For TINK 1.5" EPD	Module Number	TINK-EPD154A45
Version	A/1	Page Number	29 of 33

21. Point and line standard

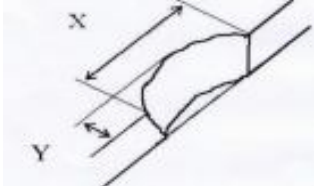
Shipment Inspection Standard						
Equipment: Electrical test fixture, Point gauge						
Outline dimension	37.32(H)×31.8(V) × 1.05(D)	Unit: mm	Part-A	Active area	Part-B	Border area
Environment	Temperature	Humidity	Illuminance	Distance	Time	Angle
	19°C~25°C	55%±5%RH	800~1300Lux	300 mm	35Sec	
Defet type	Inspection method	Standard		Part-A	Part-B	
Spot	Electric Display	D≤0.25 mm		Ignore	Ignore	
		0.25 mm < D ≤ 0.4 mm		N≤4	Ignore	
		D > 0.4 mm		Not Allow	Ignore	
Display unwork	Electric Display	Not Allow		Not Allow	Ignore	
Display error	Electric Display	Not Allow		Not Allow	Ignore	
Scratch or line defect(include dirt)	Visual/Film card	L≤2 mm, W≤0.2 mm		Ignore	Ignore	
		2.0mm < L ≤ 5.0mm, 0.2 < W ≤ 0.3mm,		N≤2	Ignore	
		L > 5 mm, W > 0.3 mm		Not Allow	Ignore	
PS Bubble	Visual/Film card	D≤0.2mm		Ignore	Ignore	
		0.2mm ≤ D ≤ 0.35mm & N≤4		N≤4	Ignore	
		D > 0.35 mm		Not Allow	Ignore	
Side Fragment	Visual/Film card	X≤5mm, Y≤0.5mm, Do not affect the electrode circuit, Ignore				
						
Remark	1. Cannot be defect & failure cause by appearance defect;					
	2. Cannot be larger size cause by appearance defect;					
	L=long W=wide D=point size N=Defects NO					

File Name	Specification For TINK 1.5" EPD	Module Number	TINK-EPD154A45
Version	A/1	Page Number	30 of 33

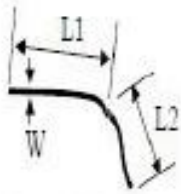

$L = L1 + L2$

Line Defect



$D = (L + W) / 2$

Spot Defect

L=long W=wide D=point size

File Name	Specification	For TINK 1.5" EPD	Module Number	TINK-EPD154A45
Version	A/1		Page Number	31 of 33

22.Barcode



AAAAAAA B CCCC DD EEE FFF GGG HH III
 ① ② ③ ④ ⑤ ⑥ ⑦ ⑧ ⑨

- ① AAAAAAA——Module of EPD
- ② B—— Normal Lot
- ③ CCCC——Date of production
- ④ DD——Production lot
- ⑤ EEE—— FPL
- ⑥ FFF——TFT
- ⑦ GGG——PS
- ⑧ HH——Edge sealing Adhesive
- ⑨ III——NO.

File Name	Specification For TINK 1.5" EPD	Module Number	TINK-EPD154A45
Version	A/1	Page Number	32 of 33

23. Packing

Packing Spec

Sheet No:

Part No	TINK-EPD154A45	DATE	2019. 4. 4	VER	A0	Page	2-1
---------	----------------	------	------------	-----	----	------	-----

一, Package Type: Box

PRODUCT DRAWING

Box No	THINGWELL shipping box
Box size	515*322*170
Containment	384PCS

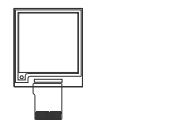
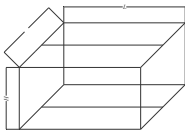

二, Inside package type: Plastic Tray
Tray unit: mm

Plastic Tray	465*280*15	13 pcs
Anti-static foil bags	700*530*0.1	1 pcs
EPE (inside)	408.17*114.75*2	24 pcs
EPE (Up-Down)	485*145*10	2 pcs
EPE (Left-Right)	285*480*10	2 pcs
EPE (Front-back)	310*145*10	2 pcs
Chip board	500*306*5	2 pcs
Quantity/tray	32 pcs	
Tray number/sheet	12+1 Sheets	
Box	1	

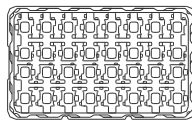

Step 1:

Material: Tray, EPE
Put the product in to the tray and keep the display side up. Then put anti-static EPE in to each holes.

Step 2:

1) Must keep the angle 180 degree placed between the neighboring Plastic trays.
2) There are 12 layers product, total 32*12=384 pcs.
3) An empty Plastic tray intersects put on the top of the plastic trays.

Step 3:

1) In each case, put 2 bags of desiccant, then seal the trays with adhesive tapes.
2) Put the trays into foil bags.
3) heat seal the foil bags.

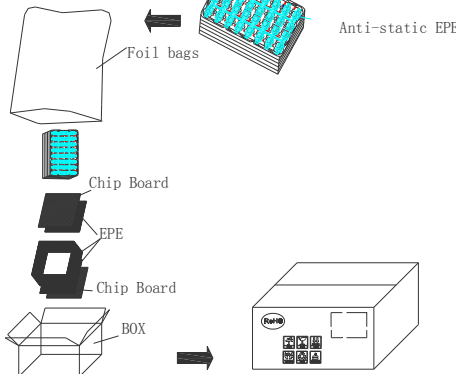

Step 4:

1) First put a chip board on the bottom of the box, then placed the down EPE, the left - right and front -back EPE.
2) Placed the sealed products into the box.
3) The last placed the up EPE on the top of the trays, and place a chip board on it.

Step 5:

1) Seal the box with adhesive tapes .
2) Paste the lable onto the exterior box, and the lable can't cover the safety , transfer and RoSH sign.

Design	X. Z. P	Approve	J. P. F	Confirm	<i>X.X.M</i>
Date	2019. 4. 4	Date	2019. 4. 4	Date	2019. 4. 4



File Name	Specification For TINK 1.5' EPD	Module Number	TINK-EPD154A45
Version	A/1	Page Number	33 of 33

Packing Spec

Sheet No

Part No	TINK-EPD154A45	Date	2019. 4. 4	VER	A0	Page	2-2
---------	----------------	------	------------	-----	----	------	-----

The label outside the carton print as below

90.00	
Label	
Customer Part No	
Customers Item No	A
MFG order No	B
MFG batch No	C
QTY	D
G. W	E
N. W	F
MFG Date	J
Carton No	
Remark	

NOTE:

1. "A" Print customer Item No
2. "B" Print customer Order No
3. "C" Print MFG Batch No (Separate packing for different batch products. Mixed packing available for the odd number of different batch print all the batch NO&QTY accordingly if happened).
4. "D" Print product qty
5. "E" Print the G. W
6. "F" Print the N. W
7. "J" Print the MFG date
8. Before packing make sure the FPL batch, item and qty are the same as which on the Final passed card.

Design	X. Z. P	Approve	J. P. F	Confirm	X.X.M
Date	2019. 4. 4	Date	2019. 4. 4	Date	2019. 4. 4