

LED SMD



Lead-Free Parts

**LG-008WK-C-D703**

**DATA SHEET**

DOC. NO : QW0905-LG-008WK-C-D703

REV. : A

DATE : 29 - Apr. - 2015



**Features:**

1. Side view white LED.
2. White SMT package.
3. Leadframe package with individual 2 pin.
4. Wide viewing angle.
5. Soldering methods: IR reflow soldering.
6. Feature of the device: more light due to higher optical efficiency; extremely wide viewing angle; ideal for backlighting and coupling in light guide.
7. Pb free

**Applications:**

1. LCD back light.
2. Mobile phones.
3. Indicators.
4. Switch lights.

**Device Selection Guide:**

PART NO	MATERIAL	COLOR	
		Emitted	Lens
LG-008WK-C-D703	InGaN	White	Yellow Diffused

**Package Dimensions**

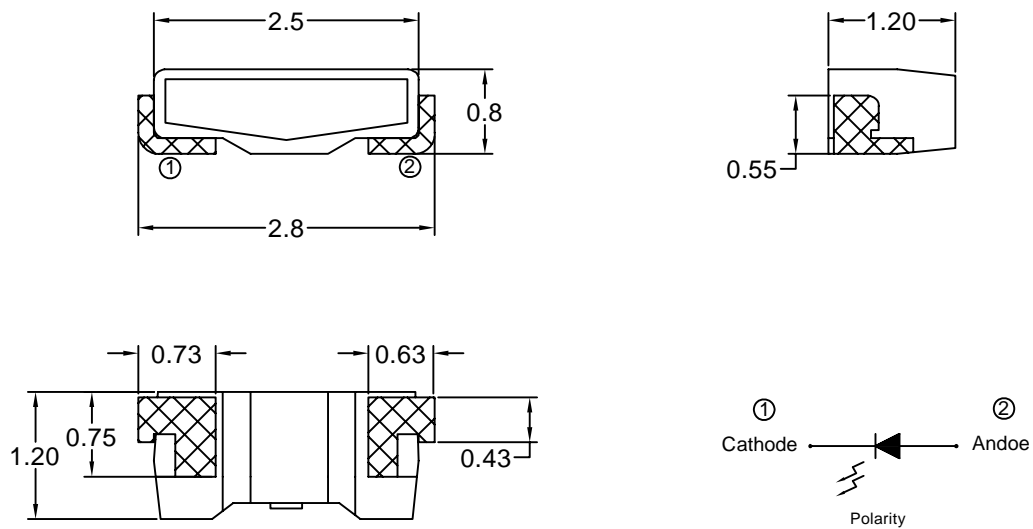

Note : 1.All dimension are in millimeter tolerance is  $\pm 0.1\text{mm}$  unless otherwise noted.  
 2.Specifications are subject to change without notice.

**Recommended Soldering Pad Dimensions**

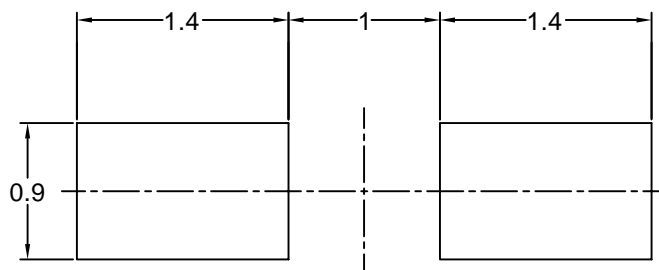

Note : The tolerances unless mentioned is  $\pm 0.1\text{mm}$ , Angle  $\pm 0.5$ . Unit=mm.

### Absolute Maximum Ratings at Ta=25 °C

Parameter	Symbol	Ratings	UNIT
Forward Current	IF	30	mA
Peak Forward Current Duty 1/10@10KHz	IFP	100	mA
Power Dissipation	PD	108	mW
Reverse Current @5V	Ir	50	μA
Electrostatic Discharge	ESD	500	V
Operating Temperature	Topr	- 20 ~ + 80	°C
Storage Temperature	Tstg	- 30 ~ + 100	°C

### Typical Electrical & Optical Characteristics (Ta=25 °C)

Items	Symbol	Min.	Typ.	Max.	UNIT	CONDITION
Luminous Intensity	Iv	1900	2100	----	mcd	IF=20mA
Chromaticity Coordinates	X	0.3028	----	0.3228	----	IF=20mA
	Y	0.3113	----	0.3481	----	IF=20mA
Forward Voltage	V <sub>F</sub>	2.8	----	3.6	V	IF=20mA
Color Rendering Index	CRI	70	----	---	----	IF=20mA
Viewing Angle	2θ 1/2	----	115	----	deg	IF=20mA

- Note : 1.The forward voltage data did not including ±0.1V testing tolerance.  
 2.The luminous intensity data did not including ±15% testing tolerance.  
 3.The color coordinates measurement allowance is ±0.01 testing tolerance.  
 4.The CRI measurement allowance is ±2 testing tolerance.

### Luminous Intensity Classification

BIN CODE	Iv(mcd) at20mA	
	Min.	Max.
W36W37	1900	2000
X11X12	2000	2100
X13X14	2100	2200
X15X16	2200	2300
X17X18	2300	2400

### Forward Voltage Classification

BIN CODE	Vf(v) at 20mA	
	Min.	Max.
1	2.8	2.9
2	2.9	3
3	3	3.1
4	3.1	3.2
5	3.2	3.3
6	3.3	3.4
7	3.4	3.5
8	3.5	3.6

**Chromaticity Coordinates Specifications For Bin Grading**

Color Coordiante at20mA								
BIN CODE	1		2		3		4	
	X	Y	X	Y	X	Y	X	Y
65K-1	0.3205	0.3481	0.3117	0.3393	0.3131	0.329	0.3213	0.3371
65K-2	0.3213	0.3371	0.3131	0.329	0.3145	0.3187	0.3221	0.3261
65K-3	0.3117	0.3393	0.3028	0.3304	0.3048	0.3209	0.3131	0.329
65K-4	0.3131	0.329	0.3048	0.3209	0.3068	0.3113	0.3145	0.3187

CIE Chromaticity Diagram

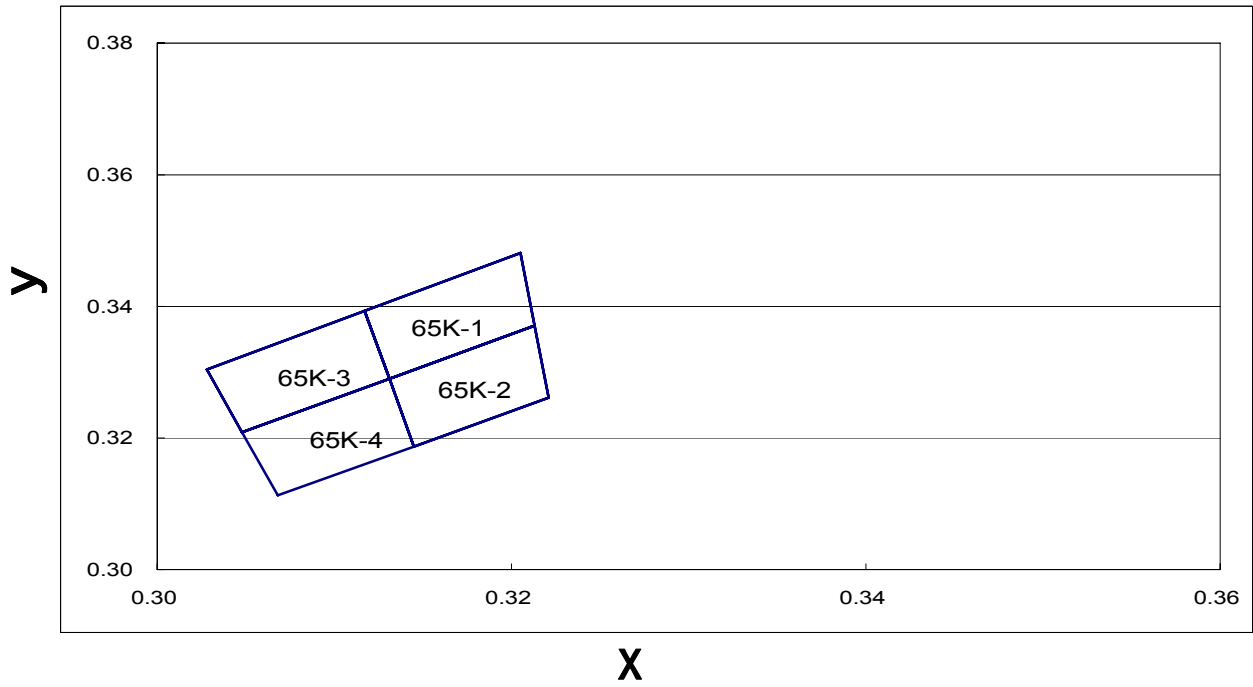

## Typical Electro-Optical Characteristics Curve

WK CHIP

Fig.1 Forward current vs. Forward Voltage

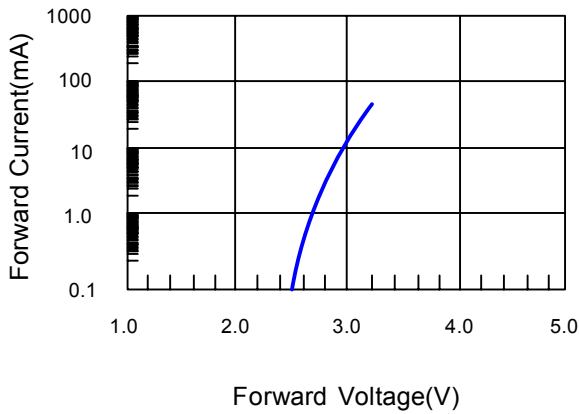

Fig.2 Relative Intensity vs. Forward Current

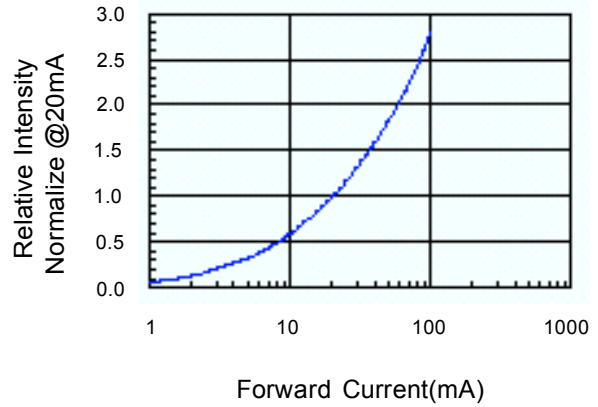

Fig.3 Forward Voltage vs. Temperature

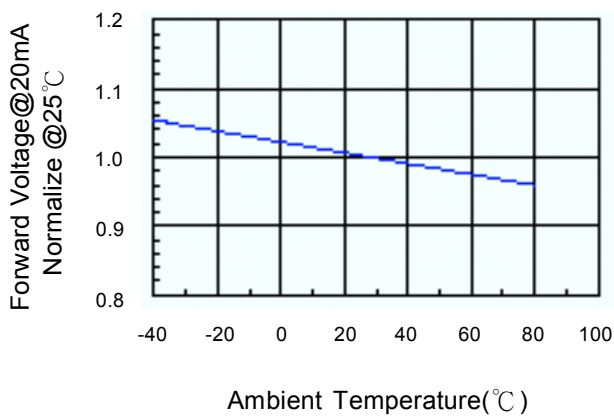

Fig.4 Relative Intensity vs. Temperature

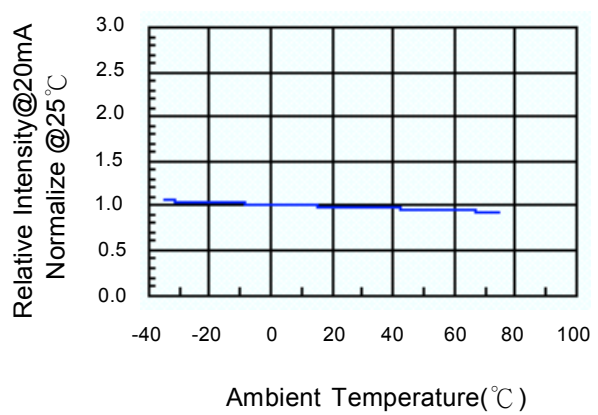

Fig.5 Luminous Spectrum (Ta=25°C)

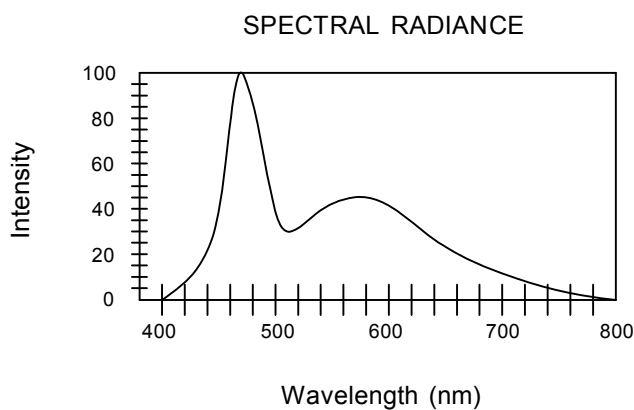
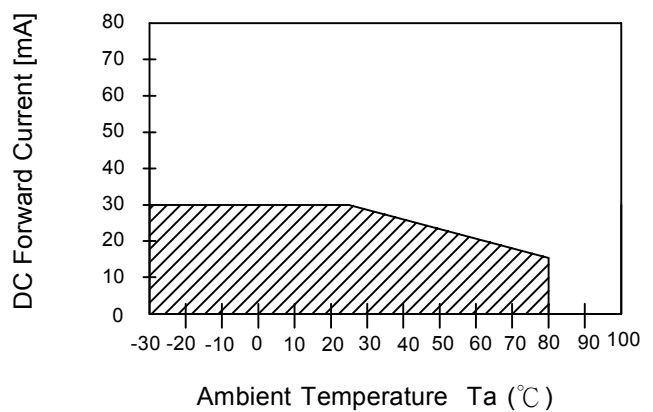
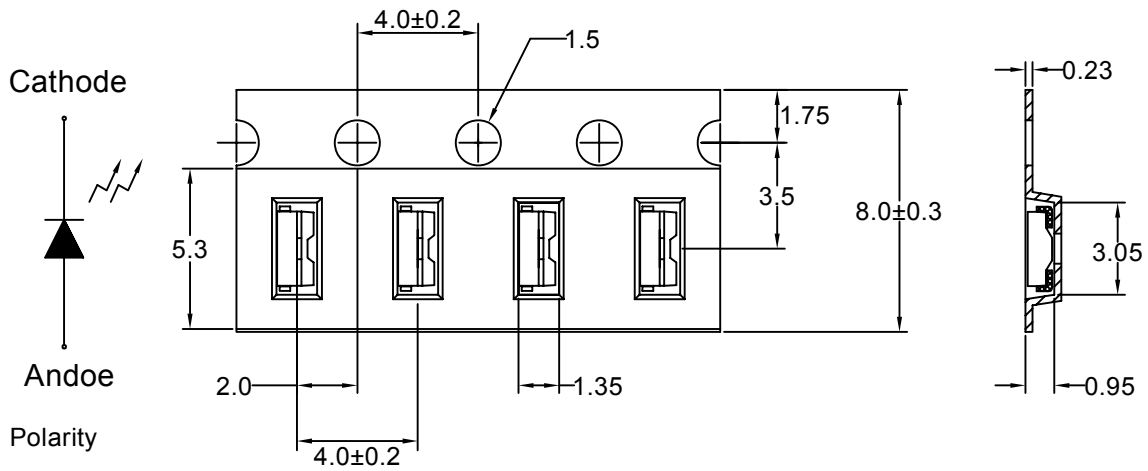

Fig.6 Forward Current vs. Temperature





## Carrier Type Dimensions







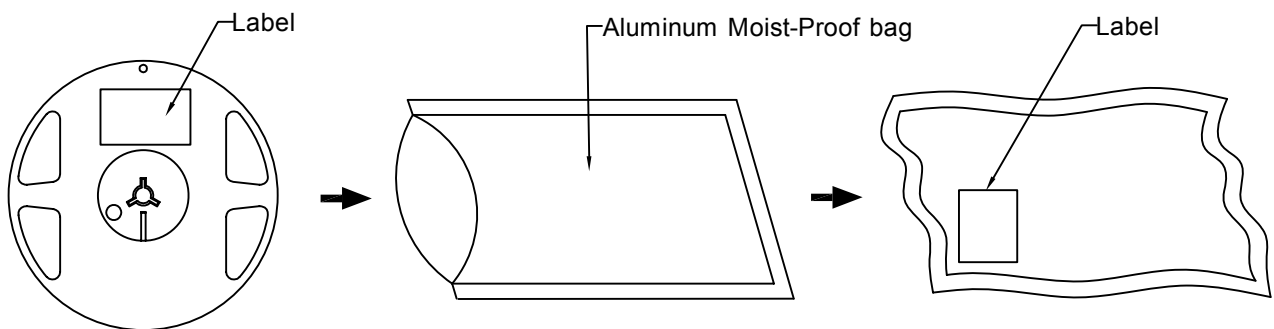

Note : The tolerances unless mentioned is  $\pm 0.1$ mm, Angle  $\pm 0.5$ . Unit=mm.

### • Packing Specifications



Part No.	Description	Quantity/Reel
LG-008WK-C-D703	8.0mm tape,7"reel	3000 devices

## Label Explanation

	LIGITEK ELECTRONICS CO., LTD.	
		
	PART :	LG-008WK-C-D703
		
	LOT :	GS11480168
		
QTY(PCS):	3000	
		
BIN/HUE :	X11X12/65K-2	VF:3.0-3.1

BIN : Luminous Intensity

HUE : Dominant Wavelength

VF : Forward Voltage

## Reel Dimensions

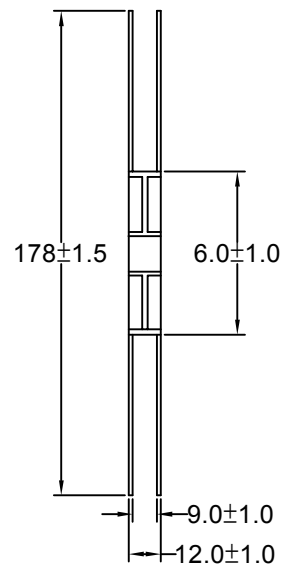
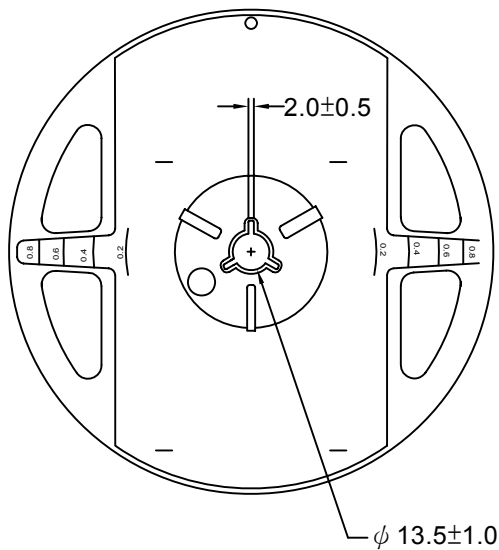

## Box Explanation

1. 5 BAG / INNER BOX
2. INNER BOX SIZE : L X W X H 23cm X 8.5cm x 26cm

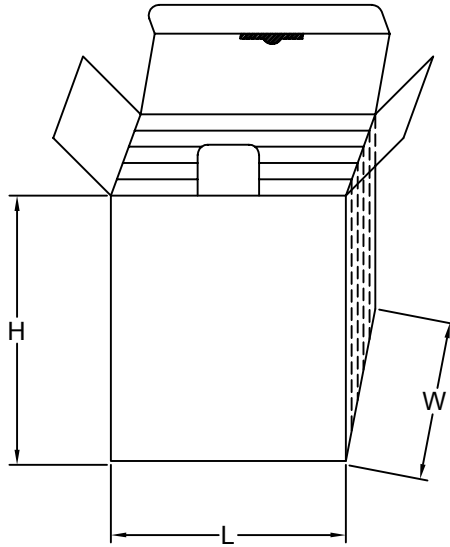

3. 10 INNER BOXES / CARTON
4. CARTON SIZE : L X W X H 58cm X 34cm x 35cm

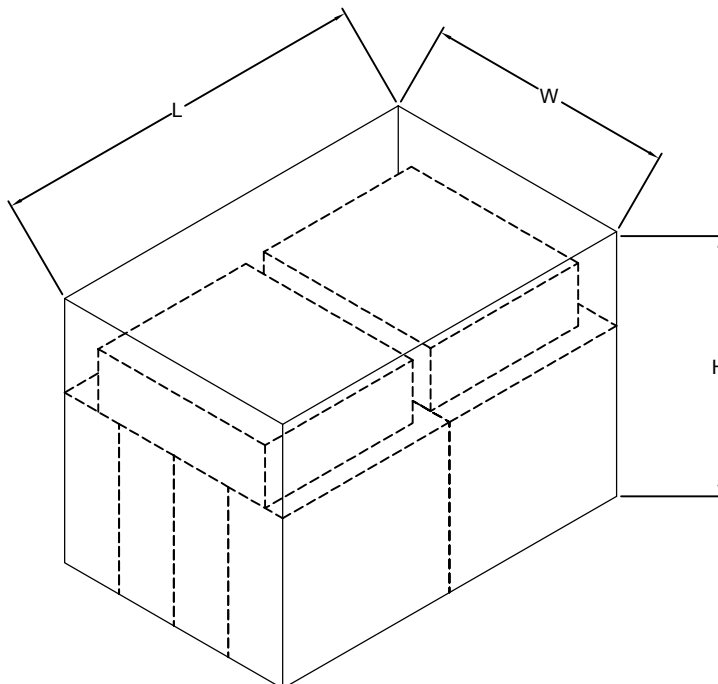

**Recommended Soldering Conditions****1. Hand Solder**

Basic spec is  $\leq 280^{\circ}\text{C}$  3 sec one time only.

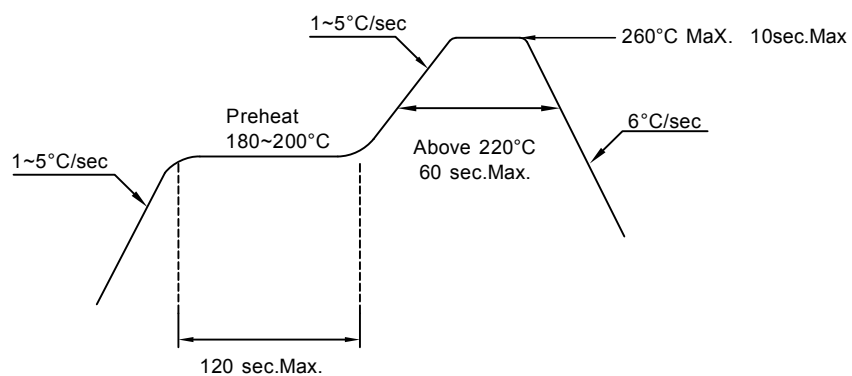
**2. PB-Free Reflow Solder****Note:**

- 1.Reflow soldering should not be done more than two times.
- 2.When soldering,do not put stress on the LEDs during heating.
- 3.After soldering,do not warp the circuit board.

**Precautions For Use:****Storage time:**

- 1.The operation of Temperatures and RH are :  $5^{\circ}\text{C}\sim 35^{\circ}\text{C}$  ,RH60%.
- 2.Once the package is opened, the products should be used within a week.  
Otherwise, they should be kept in a damp proof box with descanting agent.  
Considering the tape life, we suggest our customers to use our products within a year(from production date).
- 3.If opened more than one week in an atmosphere  $5^{\circ}\text{C} \sim 35^{\circ}\text{C}$  ,RH60%, they should be treated at  $60^{\circ}\text{C}\pm 5^{\circ}\text{C}$  for 15hrs.

**Drive Method:**

LED is a current operated device, and therefore, requirer some kind of current limiting incorporated into the driver circuit. This current limiting typically takes the form of a current limiting resistor placed in series with the LED.

Consider worst case voltage variations than could occur across the current limiting resistor. The forward current should not be allowed to change by more than 40% of its desired value.

Circuit model A

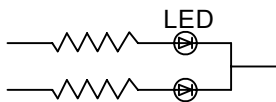

Circuit model B

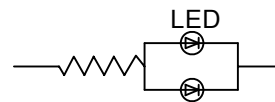

(A) Recommended circuit.

(B) The difference of brightness between LED could be found due to the VF-IF characteristics of LED.

**Cleaning:**

Use alcohol-based cleaning solvents such as isopropyl alcohol to clean the LED.

**ESD(Electrostatic Discharge):**

Static Electricity or power surge will damage the LED. Use of a conductive wrist band or anti-electrosatic glove is recommended when handing these LED. All devices, equipment and machinery must be properly grounded.

**Reliability Test:**

(1) Test items and results

Classification	Test Item	Test Condition	Sample Size
Endurance Test	Operating Life Test	1.Ta=Under Room Temperature As Per Data Sheet Maximum Rating. 2.If=20mA 3.t=1000 hrs	22
	High Temperature Storage Test	1.Ta=105°C±5°C 2.t=500 hrs	22
	Low Temperature Storage Test	1.Ta=-40°C±5°C 2.t=1000 hrs	22
	High Temperature High Humidity Storage Test	1.IR-Reflow In-Board, 2 Times 2.Ta=85°C±5°C 3.RH=90%~95% 4.t=500hrs±2hrs	22
Environmental Test	Thermal Shock Test	1.IR-Reflow In-Board,2 times 2.Ta=105°C ±5°C & -40°C±5°C (30min) (30min) 3.total 100 cycles	22
	Reflow Soldering Test	1.T.Sol=260°C ±5°C 2.Dwell Time= 10 Max.	22
	Temperature Cycling	1.105°C ~ 25°C ~ -40°C 30mins 15mins 30mins 2.100 Cyeles	22

(2) Criteria for judging the damage

Item	Symbol	Test Conditions	Criteria for Judgement	
			Min.	Max.
Forward Voltage	Vf	If=20mA	-	U.S.L x1.2
Reverse Current	Ir	Vr=5V	-	U.S.L x2.0
Luminous Intensity	Iv	If=20mA	L.S.L x 0.5	-

**Note:**

1.U.S.L.:Upper Standard Level.

2.L.S.L.:Lower Standard Level.