Getting started with AT32F415RCT7-7

Introduction

AT-START-F415 is designed to help you explore the high-performance features of the 32-bit microcontroller, AT32F415 embedded with ARM Cortex[®]-M4 core, and help develop your applications.

AT-START-F415 is an evaluation board based on AT32F415RCT7-7 chip with LED indicators, buttons, an USB micro-B connector, type A connector and Arduino[™] Uno R3 extension connector. This evaluation board embeds debugging/programming tool AT-Link-EZ without the need of other development tools.

Contents

1	Overview	5
1.1	Features	5
1.2	Definition of terms	5
2	Quick start	6
2.1	Get started.....	6
2.2	Toolchains supporting AT-START-F415	6
3	Hardware and layout	7
3.1	Power supply selection.....	9
3.2	IDD.....	9
3.3	Programming and debugging	10
3.3.1	Embedded AT-LINK-EZ.....	10
3.3.2	20-pin ARM® standard JTAG connector.....	10
3.4	Boot mode selection.....	10
3.5	External clock source	11
3.5.1	HSE clock source.....	11
3.5.2	LSE clock source.....	11
3.6	LED indicators	11
3.7	Buttons	11
3.8	USB OTG	12
3.9	0 Ω resistors	13
3.10	Extension connectors	14
3.10.1	Arduino™ Uno R3 extension connector.....	14
3.10.2	LQFP64 I/O port extension connector	15
4	Schematic	16
5	Revision history.....	20

List of tables

Table 1. Boot mode selection jumper setting.....	10
Table 2. 0 Ω resistor setting	13
Table 3. Arduino™ Uno R3 extension connector pin definition	14
Table 4. Document revision history.....	20

List of figures

Figure 1. Hardware block diagram	7
Figure 2. Top layer	8
Figure 3. Bottom layer	8
Figure 4. USB OTG interface appearance	12
Figure 5. Schematic (AT-Link-EZ)	16
Figure 6. Schematic (microcontroller).....	17
Figure 7. Schematic (power supply and peripherals).....	18
Figure 8. Schematic (extension connectors)	19

1 Overview

1.1 Features

AT-START-F415 has the following characteristics:

- AT-START-F415 has an on-board AT32F415RCT7-7 microcontroller that embeds ARM Cortex[®]-M4, 32-bit processor, 256 KB Flash memory and 32 KB SRAM, LQFP64 7x7 mm packages.
- On-board AT-Link connector:
 - The on-board AT-Link-EZ can be used for programming and debugging (AT-Link-EZ is a simplified version of AT-Link, and does not support offline mode)
 - If AT-Link-EZ is separated from this board by bending over along the joint, AT-START-F415 can be connected to an independent AT-Link for programming and debugging
- On-board 20-pin ARM standard JTAG connector (with a JTAG/SWD connector for programming/debugging)
- Various power supply methods:
 - Through the USB bus of AT-Link-EZ
 - Through the USB OTG bus (V_{BUS}) of AT-START-F415
 - External 7~12 V power supply (V_{IN})
 - External 5 V power supply (E5V)
 - External 3.3 V power supply
- 4 x LED indicators:
 - LED1 (red) used for 3.3 V power-on
 - 3 x USER LEDs, LED2 (red), LED3 (white) and LED4 (green)
- 2 x buttons (user button and reset button)
- 8 MHz HSE crystal
- 32.768 kHz LSE crystal
- On-board USB type A and micro-B connector for USB OTG function
- Various extension connectors can be quickly connected into a prototype board and easy to explore:
 - Arduino[™] Uno R3 extension connector
 - LQFP64 I/O port extension connector

1.2 Definition of terms

- **Jumper JPx ON**
Jumper installed.
- **Jumper JPx OFF**
Jumper not installed.
- **Resistor Rx ON**
Short by solder or 0Ω resistor.
- **Resistor Rx OFF**
Open.

2 Quick start

2.1 Get started

Configure the AT-START-F415 board in the following order to start the application:

1. Check the Jumper position on the board:
 - JP1 is connected to GND or OFF (BOOT0 pin is 0, and BOOT0 has an pull-down resistor in the AT32F415RCT7-7);
 - JP4 optional or OFF (BOOT1 is in any state);
 - JP6 and JP7 select the upper IO.
2. Connect the AT-START-F415 board to the PC through an USB cable (Type A to micro-B), and the board will be powered via AT-Link-EZ USB connector CN6. LED1 (red) is always on, and the other three LEDs (LED2 to LED4) start to blink in turn.
3. After pressing the user button (B2), the blink frequency of three LEDs are changed.

2.2 Toolchains supporting AT-START-F415

- ARM® Keil®: MDK-ARM™
- IAR™: EWARM

3 Hardware and layout

AT-START-F415 board is designed around an AT32F415RCT7-7 microcontroller in LQFP64 7x7 mm package.

Figure 1 shows the connections between AT-Link-EZ, AT32F415RCT7-7 and their peripherals (buttons, LEDs, USB OTG and extension connectors)

Figure 2 and *Figure 3* shows these features on the AT-Link-EZ and AT-START-F415 board.

Figure 1. Hardware block diagram

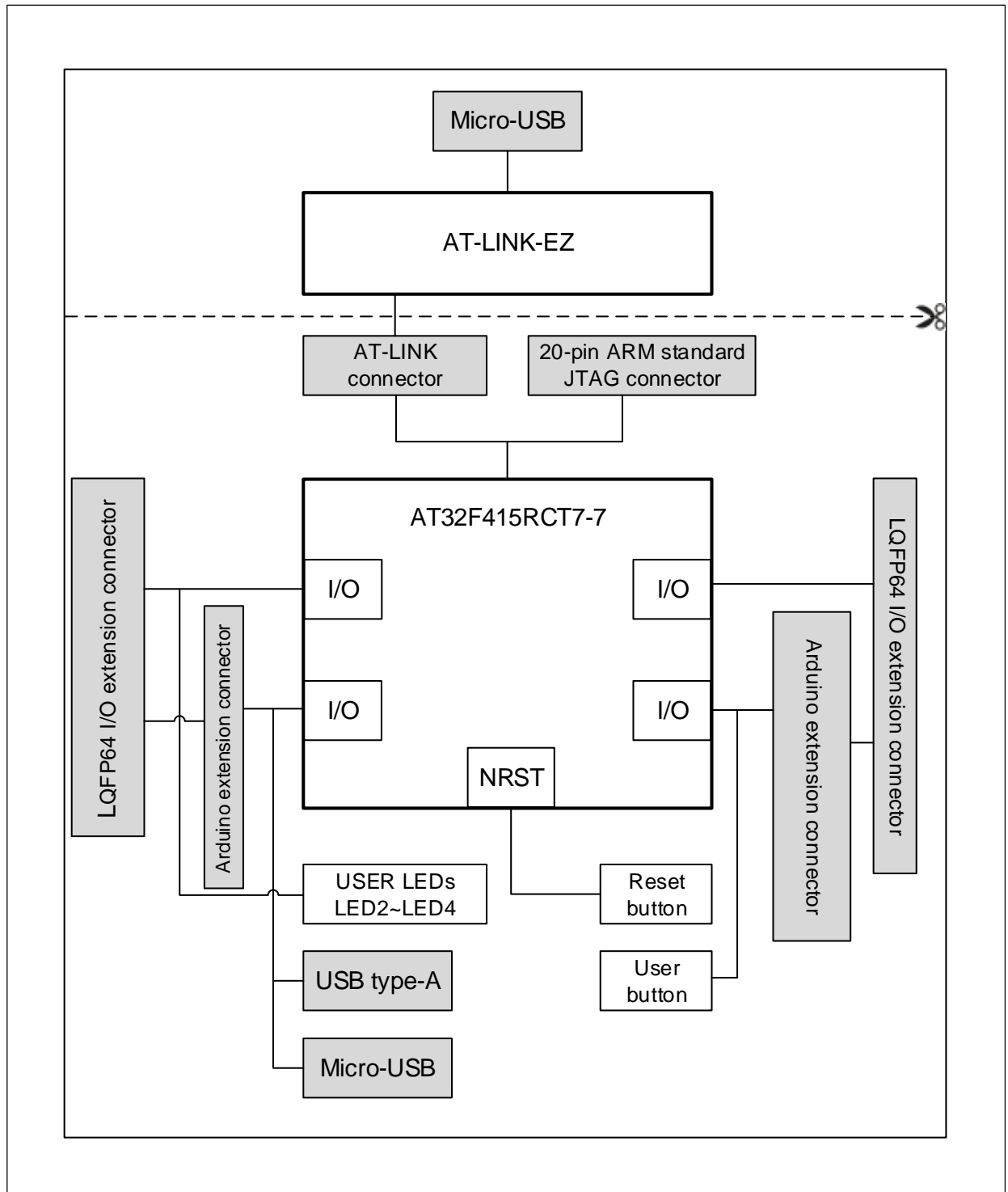

Figure 2. Top layer

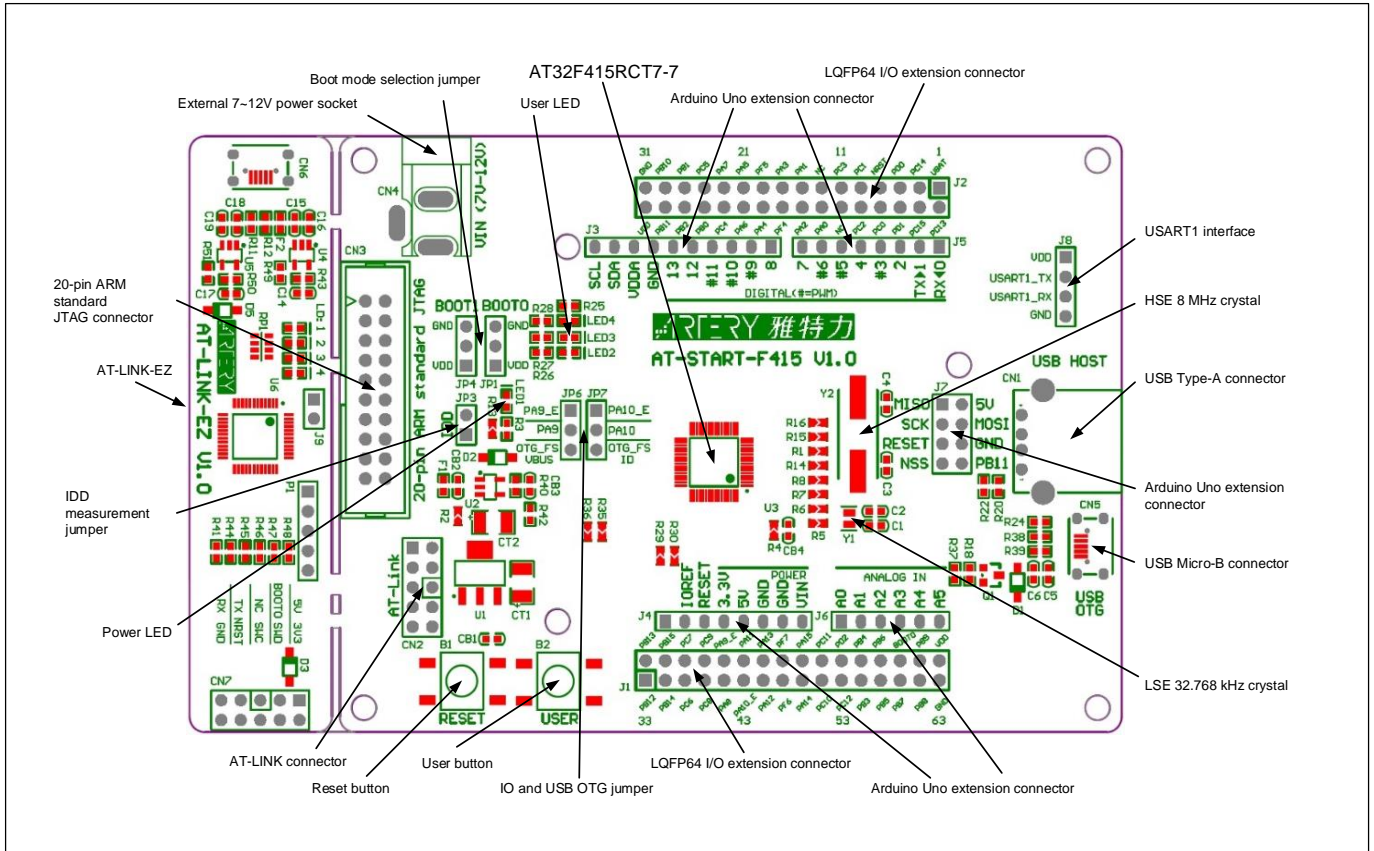
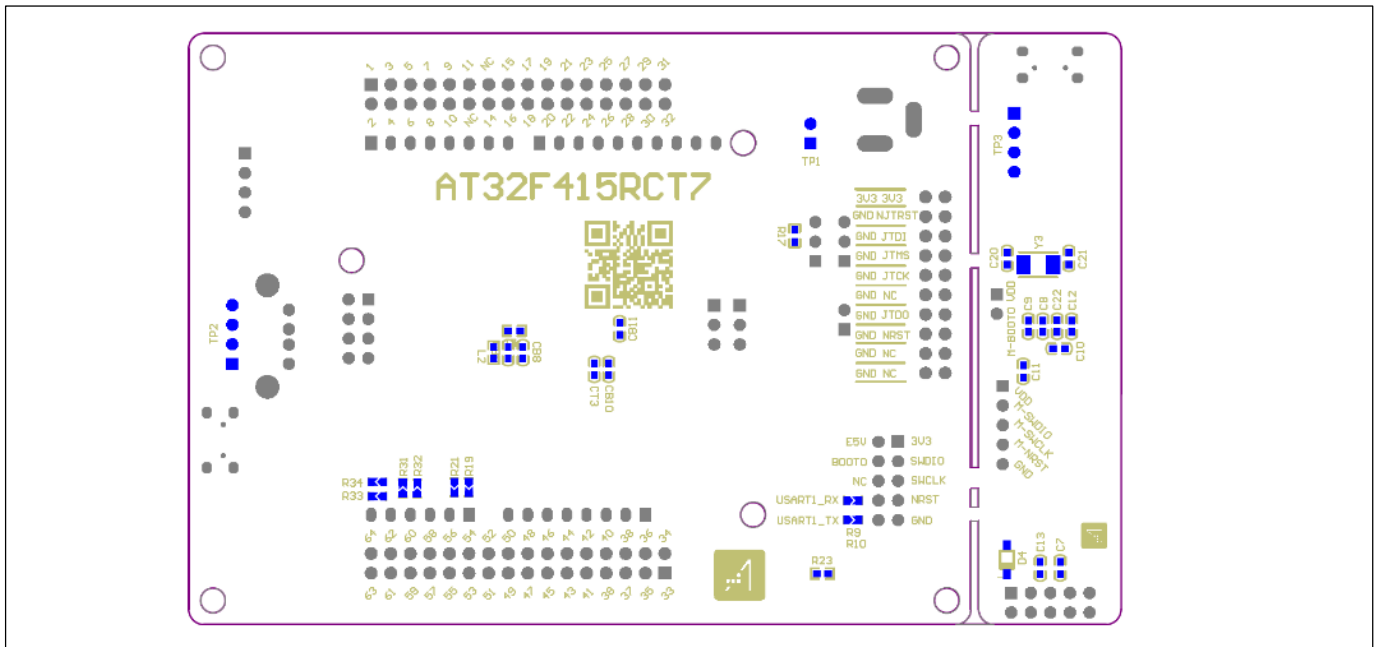

Figure 3. Bottom layer



3.1 Power supply selection

The 5 V power supply of AT-START-F415 can be provided through a USB cable (either through the USB connector CN6 on the AT-Link-EZ or USB OTG connector CN5 on the AT-START-F415), or through an external 5 V power supply (E5V), or by an external 7~12 V power supply (VIN) via 5V voltage regulator (U1) on the board. In this case, the 5 V power supply provides the 3.3 V power required by the microcontrollers and peripherals by means of the 3.3 V voltage regulator (U2) on the board.

The 5 V pin of J4 or J7 can also be used as an input power source. The AT-START-F415 board must be powered by a 5 V power supply unit.

The 3.3 V pin of J4 or the VDD pin of J1 and J2 can also be directly used as 3.3 V input power supply. AT-START-F415 board must be powered by a 3.3 V power supply unit.

Note: Unless 5 V is provided through the USB connector (CN6) on the AT-Link-EZ, the AT-Link-EZ will not be powered by other power supply methods.

When another application board is connected to J4, the VIN pin, 5 V and 3.3 V can be used as output power; J7 5V pin used as 5 V output power; the VDD pin of J1 and J2 used as 3.3 V output power.

3.2 IDD

In the event of JP3 OFF (symbol IDD) and R13 OFF, it is allowed to connect an ammeter to measure the power consumption of AT32F415RCT7-7.

- **JP3 OFF, R13 ON:**

AT32F415RCT7-7 is powered. (Default setting and JP3 plug is not mounted before shipping)

- **JP3 ON, R13 OFF:**

AT32F415RCT7-7 is powered.

- **JP3 OFF, R13 OFF:**

An ammeter must be connected to measure the power consumption of AT32F415RCT7-7 (if there is no ammeter, the AT32F415RCT7-77 cannot be powered).

3.3 Programming and debugging

3.3.1 Embedded AT-LINK-EZ

The evaluation board embeds Artery AT-Link-EZ programming and debugging tool for users to program/debug the AT32F415RCT7-7 on the AT-START-F415 board. AT-Link-EZ supports SWD interface mode and supports a set of virtual COM ports (VCP) to connect to the USART1_TX/USART1_RX (PA9/PA10) of AT32F415RCT7-7. In this case, PA9 and PA10 of AT32F415RCT7-7 will be affected by AT-Link-EZ as follows:

- PA9 is weakly pulled up to high level by the VCP RX pin of AT-Link-EZ;
- PA10 is strongly pulled up to high level by the VCP TX pin of AT-Link-EZ

The user can set R9 or R10 OFF, then the use of PA9 and PA10 of AT32F415RCT7-7 is not subject to the above restrictions.

The SWO debug port of AT-Link-EZ is connected to the TRACESWO (PB3) of AT32F415RCT7-7 via R53, and it is set in a floating state when the SWO debug function is disabled, which will not affect the use of PB3 by AT32F415RCT7-7. If you have other concerns, set R53 OFF.

Please refer to [AT-Link User Manual](#) for complete details on the operations, firmware upgrade and precautions of AT-Link-EZ.

The AT-Link-EZ PCB on the evaluation board can be separated from AT-START-F415 by bending over along the joint. In this case, AT-START-F415 can still be connected to the CN7 of AT-Link-EZ through CN2 (not mounted before shipping), or can be connected with another AT-Link to continue the programming and debugging on the AT32F415RCT7-7.

3.3.2 20-pin ARM® standard JTAG connector

AT-START-F415 also reserves JTAG or SWD general-purpose connectors as programming/debugging tools. If users want to use this interface to program and debug the AT32F415RCT7-7, please separate the AT-Link-EZ from this board or set R41, R44 and R46 OFF, and connect the CN3 (not mounted before shipping) to the programming and debugging tool.

3.4 Boot mode selection

At startup, three different boot modes can be selected by means of the pin configuration.

Table 1. Boot mode selection jumper setting

Jumper	Boot mode selection pins		Settings
	BOOT1	BOOT0	
JP1 connected to GND or OFF; JP4 optional or OFF	X	0	Boot from the internal Flash memory (Factory default setting)
JP1 connected to VDD JP4 connected to GND	0	1	Boot from the system memory
JP1 connected to VDD JP4 connected to VDD	1	1	Boot from SRAM

3.5 External clock source

3.5.1 HSE clock source

There are three hardware modes to set the external high-speed clock sources:

- **On-board crystal (default setting):**
The 8 MHz crystal on the board is used as HSE clock source. The hardware setting must be: R1 and R15 ON, R14 and R16 OFF
- **Oscillator from external PD0:**
External oscillator is injected from the pin_5 of J2. The hardware setting must be: R14 and R16 ON, R1 and R15 OFF.
- **HSE not used:**
PD0 and PD1 are used as GPIO. The hardware setting must be: R14 and R16 ON, R1 and R15 OFF.

3.5.2 LSE clock source

There are three hardware modes to set the external low-speed clock sources:

- **On-board crystal (Factory default setting):**
The 32.768 kHz crystal on the board is used as LSE clock source. The hardware settings must be: R6 and R7 ON, R5 and R8 OFF
- **Oscillator from external PC14:**
External oscillator is injected from the pin_3 of J2. The hardware setting must be: R5 and R8 ON, R6 and R7 OFF.
- **LSE not used:**
PC14 and PC15 are used as GPIO. The hardware settings must be: R5 and R8 ON, R6 and R7 OFF.

3.6 LED indicators

- **Power LED1**
Red indicates that the board is powered by 3.3 V.
- **User LED2**
Red, connected to the PC2 pin of AT32F415RCT7-7.
- **User LED3**
Yellow, connected to the PC3 pin of AT32F415RCT7-7
- **User LED4**
Green, connected to the PC5 pin of AT32F415RCT7-7

3.7 Buttons

- **Reset button B1:**
Connected to NRST to reset AT32F415RCT7-7
- **User button B2:**
It is, by default, connected to the PA0 of AT32F415RCT7-7, and alternatively used as a wake-up button (R19 ON, R21 OFF); Or connected to PC13 and alternatively used as TAMPER-RTC button (R19 OFF, R21 ON)

3.8 USB OTG

AT-START-F415 board supports USB full-speed/low-speed host or full-speed device communication mode through an USB micro-B connector (CN5). In device mode, AT32F415RCT7-7 can be directly connected to the host through USB micro-B, and V_{BUS} can be used as 5 V power supply of AT-START-F415 board; In host mode, an external USB OTG cable is required to connect to the device, and it controls the power supply of USB micro-B connector to the device by controlling the transistor S8550 through a PD2 port.

In addition, AT-START-F415 board also has an additional USB type A connector (CN1), which is an USB host connector mainly for connecting to U disk and other devices without the need of USB OTG cable. USB type A connector is without power switch control.

Figure 4. USB OTG interface appearance

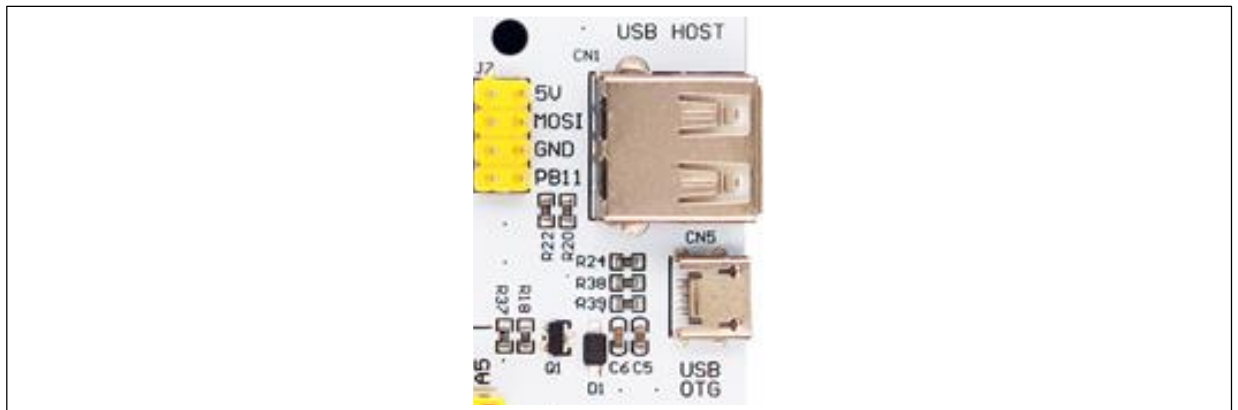

When the PA9 or PA10 of AT32F415RCT7-7 is used as OTG_FS_VBUS or OTG_FS_ID function, JP6 or JP7 should select the lower OTG_FS. In this case, PA9 or PA10 is connected to the USB micro-B connector and disconnected from Arduino™ Uno R3 extension connectors (J3~J7), LQFP64 I/O extension connectors (J1 and J2) and AT-Link connector (CN2).

3.9 0 Ω resistors

Table 2. 0 Ω resistor setting

Resistors	State ⁽¹⁾	Description
R13 (Microcontroller power consumption measurement)	ON	When JP3 is OFF, 3.3V is connected to the microcontroller to provide power supply for AT32F415RCT7-7
	OFF	When JP3 is OFF, 3.3V allows an ammeter to be connected to measure the power consumption of AT32F415RCT7-7 (if no ammeter, AT32F415RCT7-7 cannot be powered)
R4 (V _{BAT} power supply)	ON	V _{BAT} is connected to VDD
	OFF	V _{BAT} can be powered by the pin_1 VBAT of J2
R1, R14, R15, R16 (HSE)	ON, OFF, ON, OFF	HSE clock source uses crystal Y2 on the board
	OFF, ON, OFF, ON	HSE clock source is from external PD0 or PD0 and PD1 are used as GPIO.
R5, R6, R7, R8 (LSE)	OFF, ON, ON, OFF	LSE clock source uses crystal Y1 on the board
	ON, OFF, OFF, ON	LSE clock source is from external PC14 or PC14 and PC15 are used as GPIO.
R19, R21 (User button B2)	ON, OFF	User button B2 is connected to PA0
	OFF, ON	User button B2 is connected to PC13
R29, R30 (PA11, PA12)	OFF, OFF	When PA11 and PA12 are used as USB, they are not connected to pin_12 and pin_13 of J1
	ON, ON	When PA11 and PA12 are not used as USB, they can be connected to pin_12 and pin_13 of J1
R31, R32, R33, R34 (Arduino™ A4, A5)	OFF, ON, OFF, ON	Arduino™ A4 and A5 are connected to ADC1_IN11, and ADC1_IN10
	ON, OFF, ON, OFF	Arduino™ A4 and A5 are connected to I2C1_SDA and I2C1_SCL
R35, R36 (Arduino™ D10)	OFF, ON	Arduino™ D10 is connected to SPI1_SS
	ON, OFF	Arduino™ D10 is connected to PWM (TMR4_CH1)
R9 (USART1_RX)	ON	USART1_RX of AT32F415RCT7-7 is connected to VCP TX of AT-LINK-EZ
	OFF	USART1_RX of AT32F415RCT7-7 is disconnected from VCP TX of AT-LINK-EZ
R10 (USART1_TX)	ON	USART1_TX of AT32F415RCT7-7 is connected to VCP RX of AT-LINK-EZ
	OFF	USART1_TX of AT32F415RCT7-7 is disconnected from VCP RX of AT-LINK-EZ

(1) The factory default Rx state is shown in BOLD.

3.10 Extension connectors

3.10.1 Arduino™ Uno R3 extension connector

Female plug J3~J6 and male J7 support standard Arduino™ Uno R3 connectors. Most of the daughter boards designed around Arduino™ Uno R3 are suitable for AT-START-F415.

Note 1: The I/O ports of AT32F415RCT7-7 are 3.3 V compatible with Arduino™ Uno R3, but 5V incompatible.

Note 2: The pin_8 of J3 is VDDA, which has the same level as VDD, without AFEF function defined by Arduino™ Uno R3.

Table 3. Arduino™ Uno R3 extension connector pin definition

Connector	Pin number	Arduino pin name	AT32F415 pin name	Functions
J4 (Power supply)	1	NC	-	-
	2	IOREF	-	3.3V reference
	3	RESET	NRST	External reset
	4	3.3V	-	3.3V input/output
	5	5V	-	5V input/output
	6	GND	-	Ground
	7	GND	-	Ground
	8	VIN	-	7~12V input/output
J6 (Analog input)	1	A0	PA0	ADC1_IN0
	2	A1	PA1	ADC1_IN1
	3	A2	PA4	ADC1_IN4
	4	A3	PB0	ADC1_IN8
	5	A4	PC1 or PB9 ⁽¹⁾	ADC1_IN11 or I2C1_SDA
	6	A5	PC0 or PB8 ⁽¹⁾	ADC1_IN10 or I2C1_SCL
J5 (Logic input/output low byte)	1	D0	PA3	USART2_RX
	2	D1	PA2	USART2_TX
	3	D2	PA10	-
	4	D3	PB3	TMR2_CH2
	5	D4	PB5	-
	6	D5	PB4	TMR3_CH1
	7	D6	PB10	TMR2_CH3
	8	D7	PA8	-
J3 (Logic input/output high byte)	1	D8	PA9	-
	2	D9	PC7	TMR1_CH2
	3	D10	PA15 or PB6 ⁽¹⁾	SPI1_NSS or TMR4_CH1
	4	D11	PA7	TMR3_CH2 or SPI1_MOSI
	5	D12	PA6	SPI1_MISO
	6	D13	PA5	SPI1_SCK
	7	GND	-	Ground
	8	VDDA	-	VDDA output
	9	SDA	PB9	I2C1_SDA
	10	SCL	PB8	I2C1_SCL

Connector	Pin number	Arduino pin name	AT32F415 pin name	Functions
J7 (Others)	1	MISO	PB14	SPI2_MISO
	2	5V	-	5V input/output
	3	SCK	PB13	SPI2_SCK
	4	MOSI	PB15	SPI2_MOSI
	5	RESET	NRST	External reset
	6	GND	-	Ground
	7	NSS	PB12	SPI2_NSS
	8	PB11	PB11	-

(1) 0Ω resistor setting is shown in [Table 2](#).

3.10.2 LQFP64 I/O port extension connector

The extension connectors J1 and J2 can connect the AT-START-F415 to external prototype/packing board. The I/O ports of AT32F415RCT7-7 are available on these extension connectors. J1 and J2 can also be measured with oscilloscope, logic analyzer or voltmeter probe.

4 Schematic

Figure 5. Schematic (AT-Link-EZ)

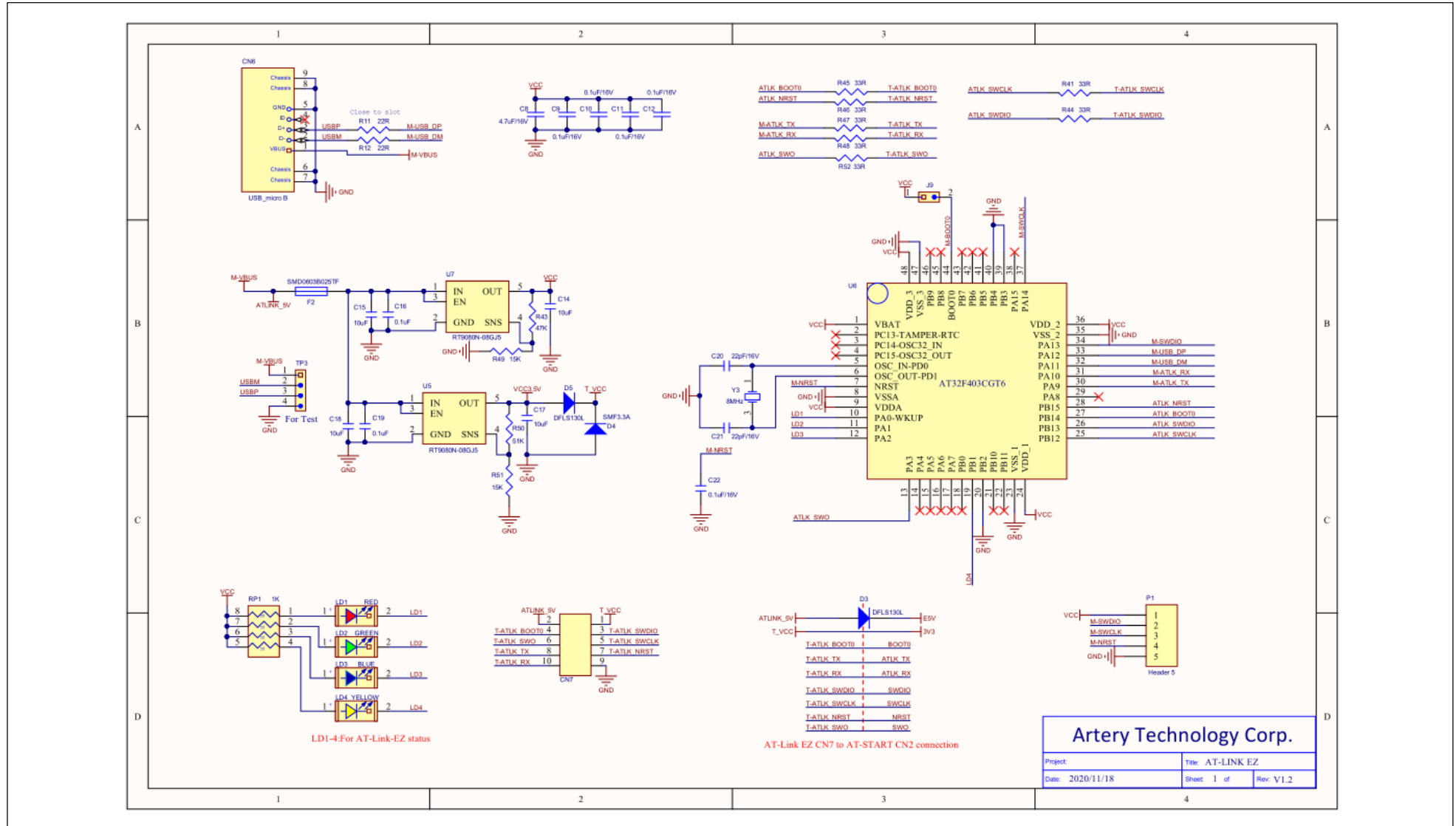

Figure 6. Schematic (microcontroller)

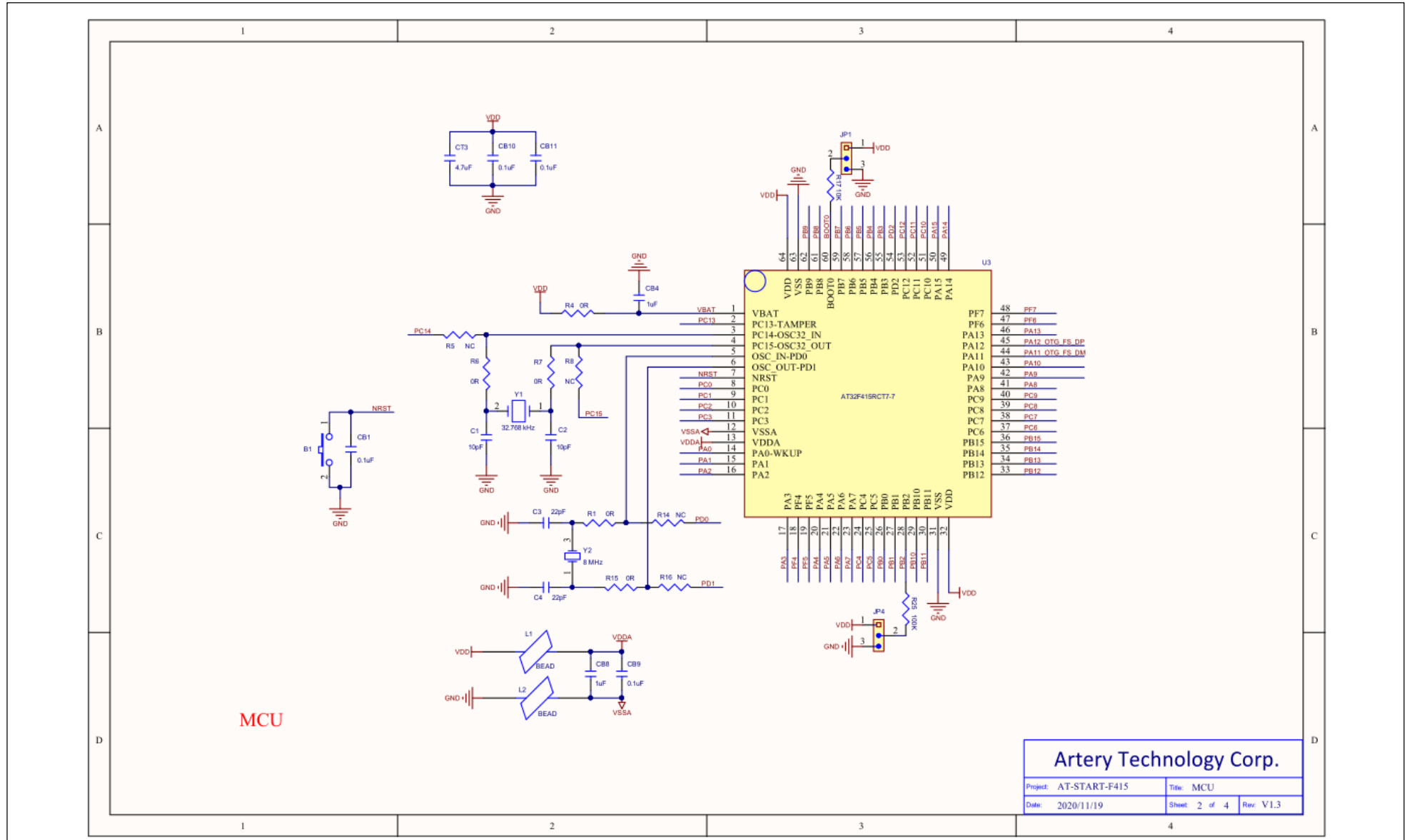
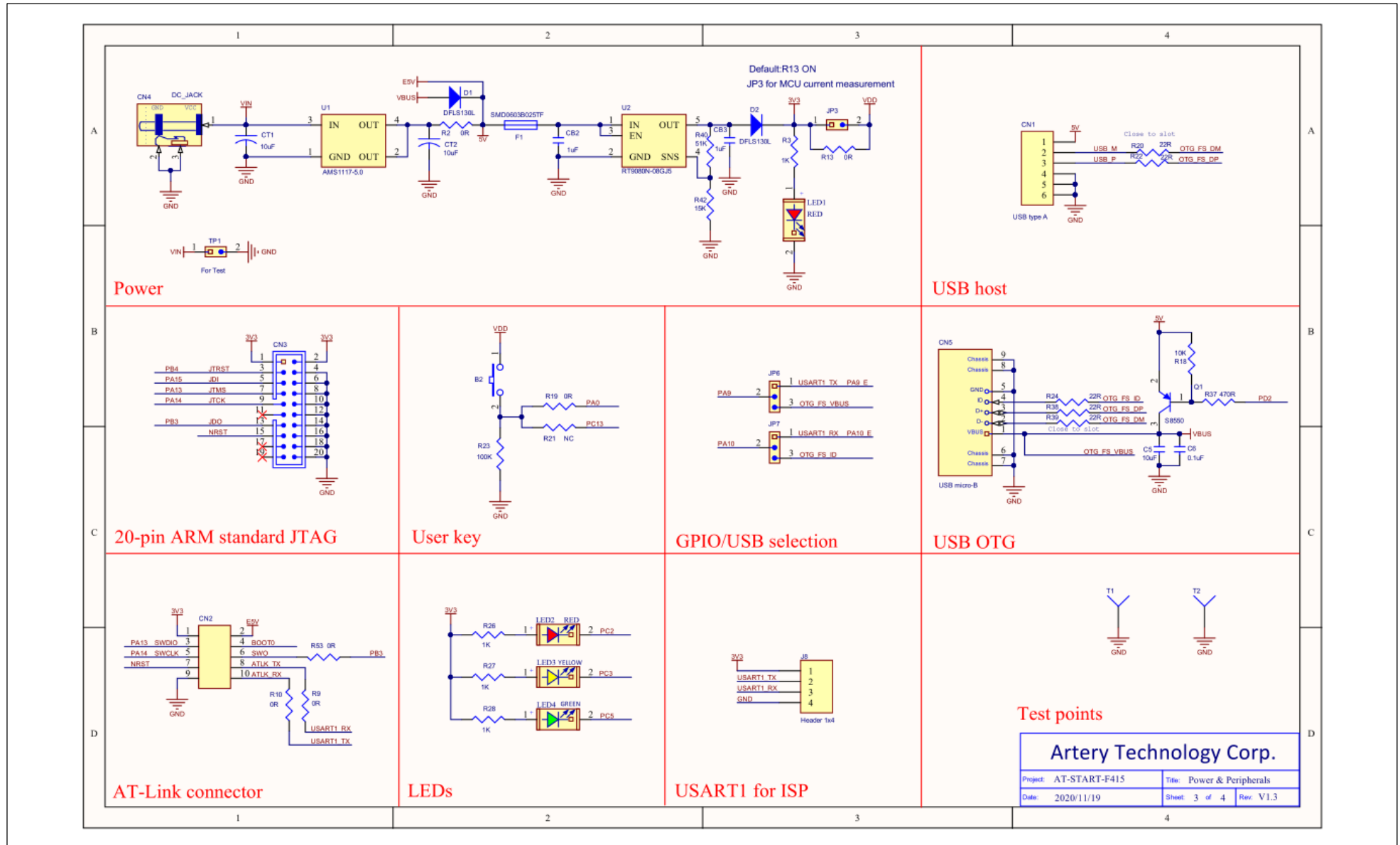

Figure 7. Schematic (power supply and peripherals)



Artery Technology Corp.

Project: AT-START-F415	Title: Power & Peripherals
Date: 2020/11/19	Sheet: 3 of 4 Rev: V1.3

Figure 8. Schematic (extension connectors)

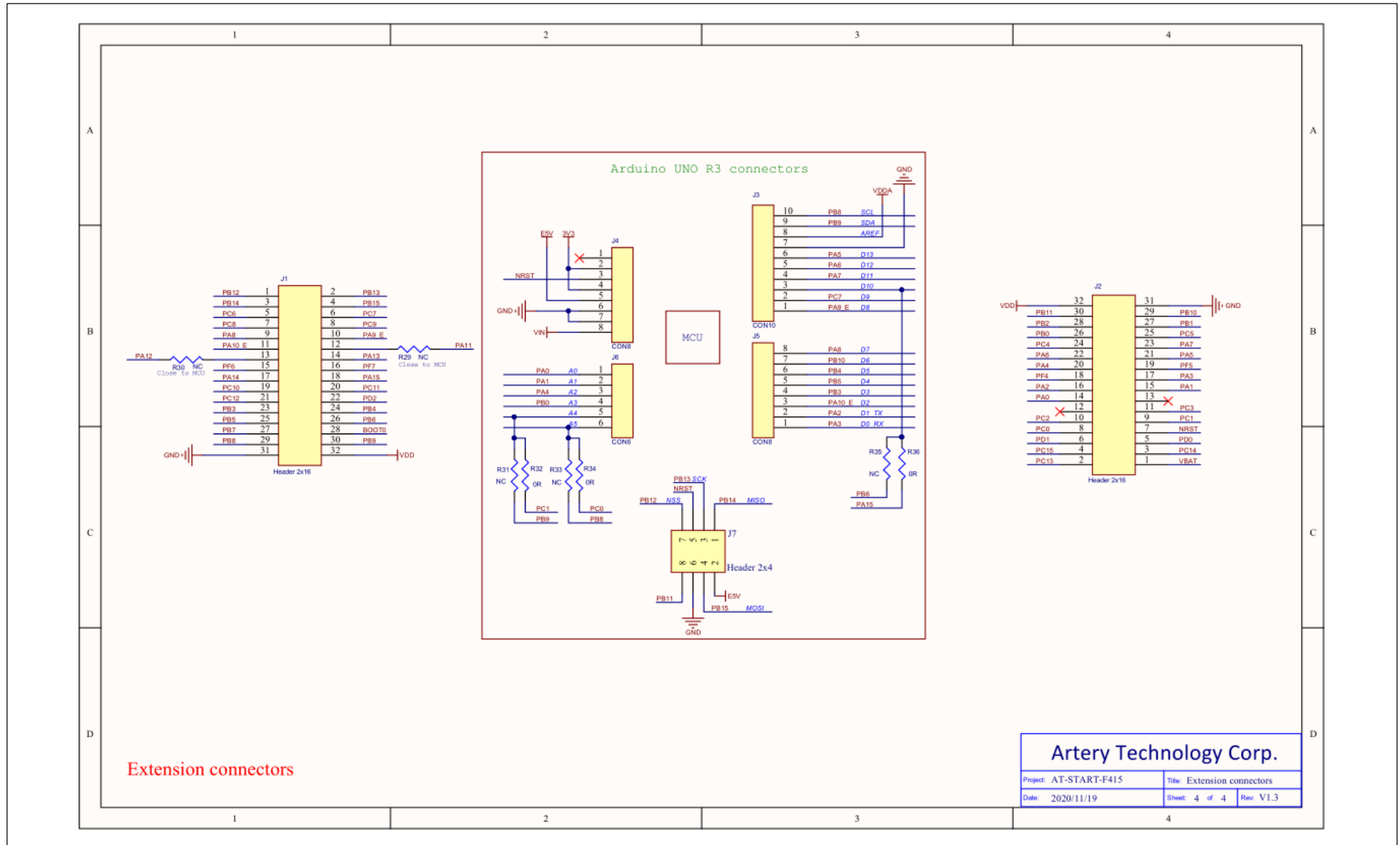

5 Revision history

Table 4. Document revision history

Date	Revision	Changes
2019.8.16	1.0	Initial release
2020.6.1	1.1	<ol style="list-style-type: none"> 1. Modified CB8 to 1 μF. 2. Corrected the silkscreen on the back side to AT32F415RCT7-7. 3. Replaced 8 MHz crystal. 4. Optimized the direction of solder bridge. 5. Changed the LED3 to yellow.
2020.9.29	1.20	<ol style="list-style-type: none"> 1. Changed the revision code of this document to 3 digits, with the first two for AT-START hardware version, and the last one for the document. 2. Updated the version of AT-Lin-EZ to 1.1 to support SWO debug; and Added SWO description.
2020.11.19	1.30	<ol style="list-style-type: none"> 1. Updated the version of AT-Link-EZ to 1.2, and adjusted two rows of CN7 signals, and modified the silkscreen. 2. Modified the CN2 silkscreen in accordance with Artery development tools. 3. Added GND test pin ring to facilitate measurement.

IMPORTANT NOTICE – PLEASE READ CAREFULLY

Purchasers understand and agree that purchasers are solely responsible for the selection and use of Artery's products and services.

Artery's products and services are provided "AS IS" and Artery provides no warranties express, implied or statutory, including, without limitation, any implied warranties of merchantability, satisfactory quality, non-infringement, or fitness for a particular purpose with respect to the Artery's products and services.

Notwithstanding anything to the contrary, purchasers acquires no right, title or interest in any Artery's products and services or any intellectual property rights embodied therein. In no event shall Artery's products and services provided be construed as (a) granting purchasers, expressly or by implication, estoppel or otherwise, a license to use third party's products and services; or (b) licensing the third parties' intellectual property rights; or (c) warranting the third party's products and services and its intellectual property rights.

Purchasers hereby agrees that Artery's products are not authorized for use as, and purchasers shall not integrate, promote, sell or otherwise transfer any Artery's product to any customer or end user for use as critical components in (a) any medical, life saving or life support device or system, or (b) any safety device or system in any automotive application and mechanism (including but not limited to automotive brake or airbag systems), or (c) any nuclear facilities, or (d) any air traffic control device, application or system, or (e) any weapons device, application or system, or (f) any other device, application or system where it is reasonably foreseeable that failure of the Artery's products as used in such device, application or system would lead to death, bodily injury or catastrophic property damage.