

GOT812LR-834

12.1" XGA TFT IP66-rated Sunlight Readable Fanless Touch Panel Computer (-20°C ~ +55°C)

NEW

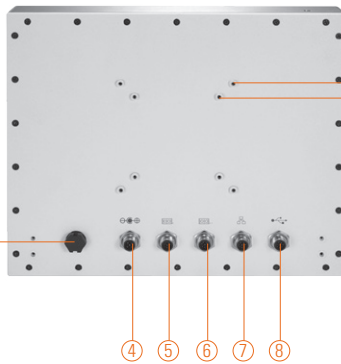

VESA 100
VESA 75

1. Backlight switch
2. Brightness adjust
3. Power switch (ATX)
4. DC power connector
5. COM 1 (RS-232/422/485)
6. COM 2 (RS-232/422/485)
7. Ethernet
8. USB 2.0 x 2



Features

- Sunlight readable 12.1" XGA high brightness (1000 nits)
- Low-reflective color TFT LCD
- Water/dust/corrosion-proof design IP66 (NEMA4X)
- Type 316 stainless steel front bezel
- Wide operating temperature range of -20°C ~ +55°C
- Fanless system with Intel® Atom™ processor E3827 1.75 GHz
- Wireless network connectivity
- Flexible and expandable with variety of M12 type I/O connections
- Designed and tested according to IEC60945 and DNV 2.4 standards
- Supports suspension and VESA mount
- All I/O are M12 connectors

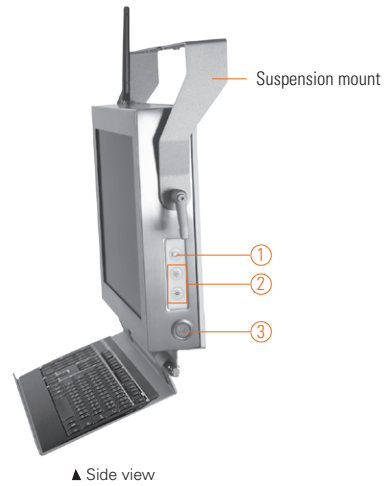

▲ Side view

Introduction

The GOT812LR-834 is specially designed for heavy-duty & outdoor applications. Its IP66-rating stainless steel housing protects entire system from outside damage of water, powder and dust. It also outfits sunlight readable technology and wide operating temperature range of -20°C ~ +55°C. Thus, this robust unit is best suited for outdoor environments in extreme sunny or rainy day, dusty or wet spaces in food factories or kitchens and more harsh applications, such as steel factories, transformer stations and vessels.

IP66-sealed system

The GOT812 adopts a water/dust-proof housing design and five IP66-rated connectors. It passes entire system IP66 test by SGS and verified salt mist test and marine grade by IEC60945.

Sunlight readable design

Its sunlight readable technology with LED tech high brightness 1000 nits color display and low reflective touchscreen allows the screen legible even under strong sunlight.

Wide temp. (-20°C ~ +55°C) & anti-vibration (2G) design

The GOT812 supports wide temperature of -20°C ~ +55°C. Besides, the patent of anti-vibration for SSD ensures system reliability and stability.

Specifications

Front Bezel	Stainless type 316	
LCD Panel	Display Type	12.1" XGA TFT LCD
	Brightness (cd/m ²)	1000 nits
	Resolution	1024 x 768
	Viewing Angle (H/V)	160°/140°
Main System	CPU	Intel® Atom™ processor E3827 1.75 GHz
	System Memory	2 x 204-pin DDR3L SO-DIMM max. up to 8 GB
BIOS	AMI with Axiomtek standard features; such as, SmartView, Ethernet Boot ROM (RPL & PXE), customer CMOS backup	
Storage	1 x 2.5" SSD	
	1 x CompactFlash™	
Watchdog Timer	255 levels, 1~255 sec.	
Onboard Graphics	Integrated in Intel® GFX	

Specifications

I/O Connector	2 x RS-232/422/485 (default RS-232) 2 x USB 2.0 1 x 10/100/1000Mbps Ethernet
Expansion Interface	2 x PCIe Mini Card slot
Touchscreen	2-wire resistive low reflective type
Power Supply	Power input 10-30VDC
Dimensions	304 mm (11.97") (W) x 58.5 mm (2.3") (D) x 248 mm (9.76") (H)
Packing Dimensions	380 mm (14.96") (W) x 190 mm (7.48") (D) x 430 mm (16.93") (H)
Weight (net/gross)	3.6 kg (7.94 lb) / 6.2 kg (13.67 lb)
Environment	Operating temperature: -20°C ~ +55°C Storage Temperature: -30°C ~ +80°C (-22°F ~ +176°F) Relative humidity: 10% ~ 95% @ 40°C, non-condensing Operation vibration: 2G, 5 ~ 500Hz, random for 2.5" SSD 2G, 5 ~ 500Hz, random for CompactFlash™
Certification	CE/IEC60945/DNV 2.4 (compliant) (GOT812LR)

* W.T.: Wide Temperature. All W.T. supported products have to be sorted by Axiomtek.

Optional Accessories

822B8120070E	GOT812 keyboard bracket (w/o keyboard)
822B8120080E	GOT812 suspension kit
594B8122100E	Water-proof COM port cable (1.8m)
594B8122820E	Water-proof USB cable (1.8m)
594B8122720E	Water-proof LAN cable (1.8m)
50964A23000E	72W/24V power adapter with M12 connector

Dimensions

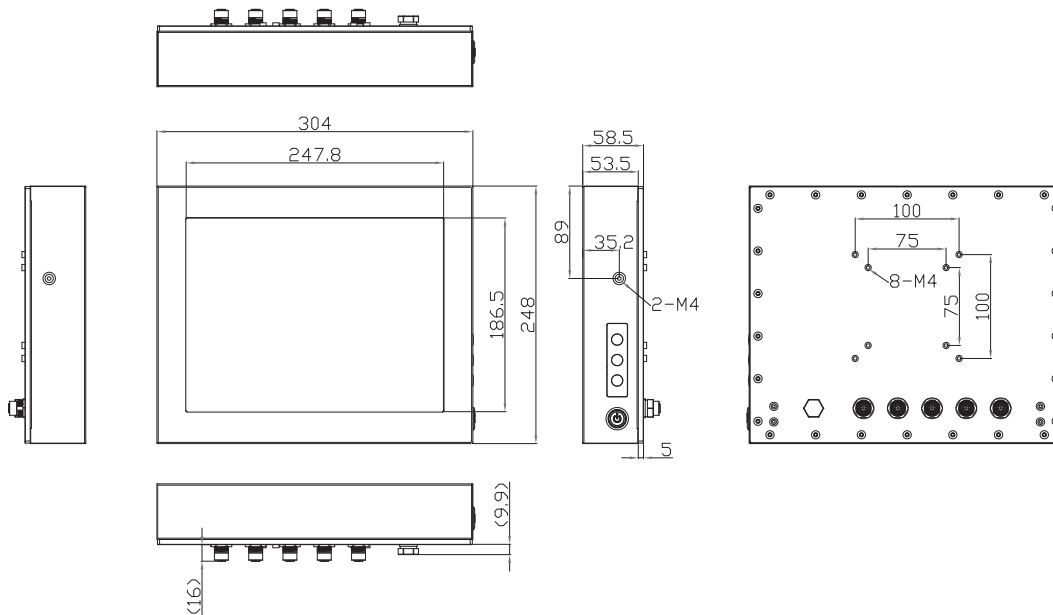

Ordering Information

Sunlight readable type	
GOT812LR-834-DC	12.1" IP66-rated heavy-duty sunlight readable touch panel computer (1000 nits) with Intel® Atom™ E3827
GOT812LR-834-RF-DC	12.1" IP66-rated heavy-duty sunlight readable touch panel computer with Intel® Atom™ E3827 and WiFi or 3G

* Specification and certifications are based on options and may vary.

Optional EOS Installation

WES 7
WES 8

Optional OS Installation

Windows® 7
Windows® 8/8.1

Overview

Industrial Panel Computers & Monitors

Heavy-duty Fanless Touch Panel Computers

Digital Signage Solutions

Healthcare & Medical Solutions

Open Frame Panel Computers

Accessories