



RoHS

# Specification

Client Name: \_\_\_\_\_

Client P/N: \_\_\_\_\_

Factory P/N: HL-AF-5060U32YC-3-S1-T1

Sending Date: \_\_\_\_\_

| Client approval   |       |              | Hong li approval |  |              |
|---|-------|--------------|------------------|--|--------------|
| Approval  | Audit | Confirmation | Approval         | Audit  | Confirmation |
|   |       |              | 殷小平              |  | 王佩           |
| <input type="checkbox"/> Qualified <input type="checkbox"/> Unqualified |       |              | DATE: _____      |  |              |

Adr: West side of Dongfeng Highway, Auto City, Huadu

District, Guangzhou, China

Tel: 020-86733333 (Switchboard)

Fax: 020-86733883 86733938 86733265

Web: [www.honglitronic.com](http://www.honglitronic.com)



## HL-AF-5060U32YC-3-S1-T1

### Features

- Extremely wide viewing angle
- Suitable for all SMT assembly and solder process
- Available on tape and reel
- Moisture sensitivity level: Level 4
- Package: 1000pcs/reel
- RoHS compliant

### Description

The Yellow source color devices are made with AlGaInP on Substrate Light Emitting Diode

### Applications

- Optical indicator
- Indoor display
- Interior automotive lighting
- Backlight for LCD, switch and Symbol, display
- Light pipe application
- General use

### Package Dimensions

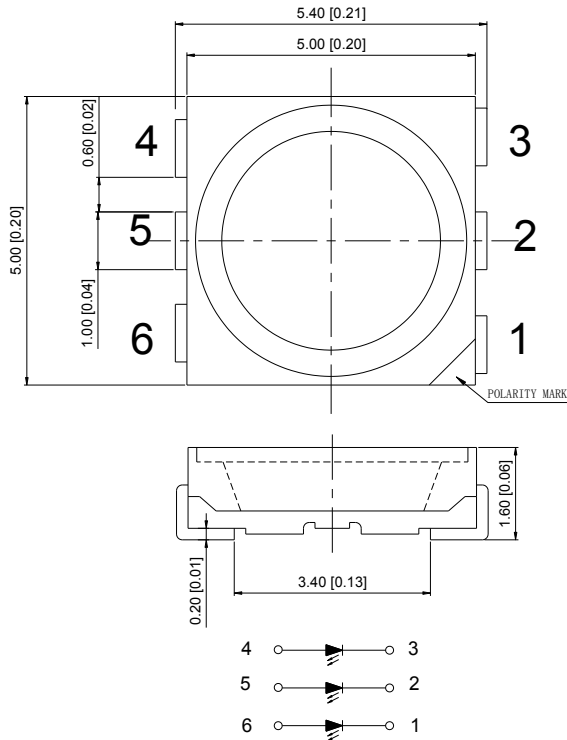

Notes:

1. All dimension units are millimeters.
2. All dimension tolerance is  $\pm 0.15$ mm unless otherwise noted.



**ATTENTION**  
OBSERVE PRECAUTIONS  
FOR HANDLING  
ELECTROSTATIC  
DISCHARGE  
SENSITIVE  
DEVICES

### Recommended Soldering Pattern

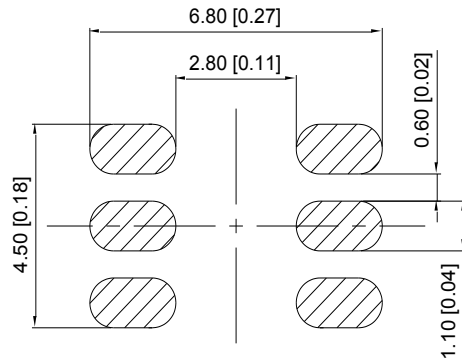



## HL-AF-5060U32YC-3-S1-T1

### Selection Guide

| Part No.                | Dice             | Lens Type   | Luminous intensity(mcd)<br>@ 20mA*3 |      | Viewing Angle |
|-------------------------|------------------|-------------|-------------------------------------|------|---------------|
|                         |                  |             | Min.                                | Typ. | θ1/2          |
| HL-AF-5060U32YC-3-S1-T1 | Yellow (AlGaInP) | Water Clear | 1700                                | 2200 | 120°          |

Note:

1. θ1/2 is the angle from optical centerline where the luminous intensity is 1/2 the optical centerline value.
- 2.the above luminous intensity measurement allowance tolerance ±10%.

### Electrical / Optical Characteristics at Ta=25°C

| Parameter           | Symbol         | Min. | Typ. | Max | Units | Test Conditions         |
|---------------------|----------------|------|------|-----|-------|-------------------------|
| Forward Voltage     | V <sub>F</sub> | 1.8  | --   | 2.4 | V     | I <sub>F</sub> =20mA *3 |
| Reverse Current     | I <sub>R</sub> | --   | --   | 10  | uA    | V <sub>R</sub> = 5V     |
| Dominate Wavelength | λ <sub>d</sub> | 586  | --   | 596 | nm    | I <sub>F</sub> =20mA *3 |

### Absolute Maximum Ratings at Ta=25°C

| Parameter                     | Rating     | Units |
|-------------------------------|------------|-------|
| Power dissipation             | 225        | mW    |
| DC Forward Current per chip   | 30         | mA    |
| Peak Forward Current [1]      | 300        | mA    |
| Reverse Voltage               | 5          | V     |
| Electrostatic Discharge (HBM) | 2000       | V     |
| Operating Temperature         | -40 ~ +85  | °C    |
| Storage Temperature           | -40 ~ +100 | °C    |

Note:

- 1.1/10 Duty Cycle, 0.1ms Pulse Width.
- 2.The above forward voltage measurement allowance tolerance ±0.1V



# HL-AF-5060U32YC-3-S1-T1

## Typical optical characteristics curves

Ambient Temperature VS. Forward Current

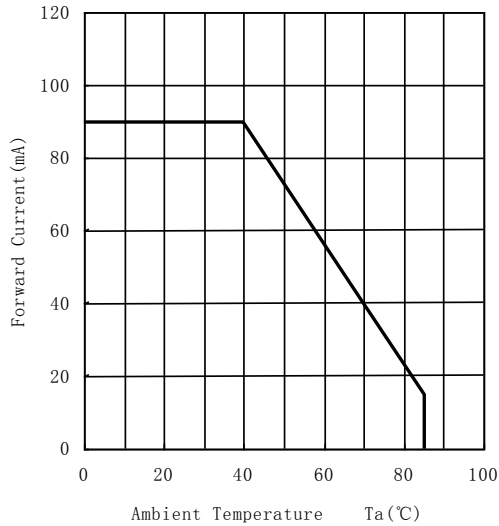

Forward Current VS. Relative Intensity

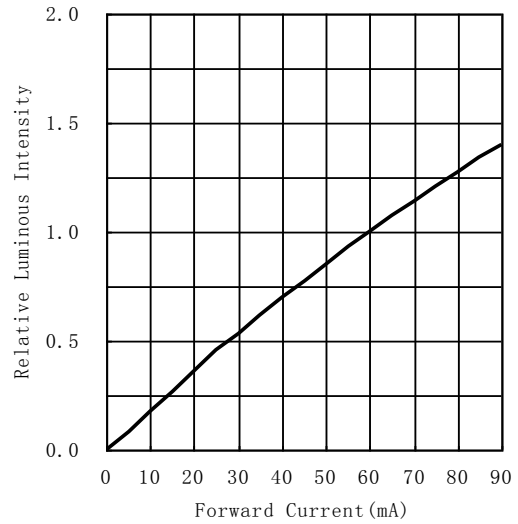

Forward Voltage VS. Forward Current

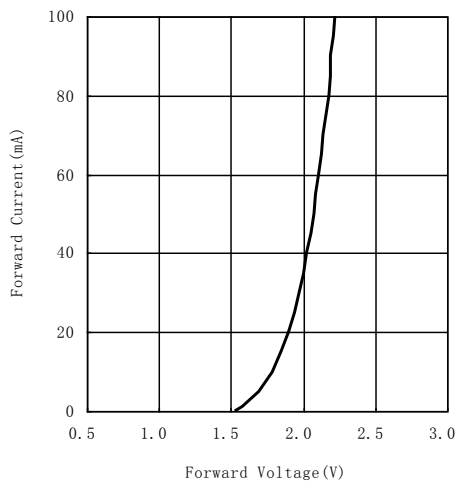

Ambient Temperature VS. Relative Intensity

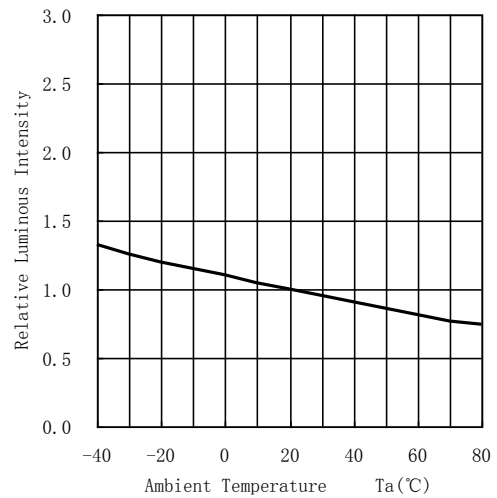

Relative spectral emission

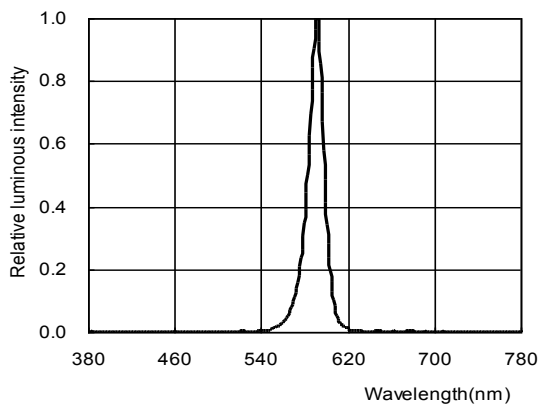
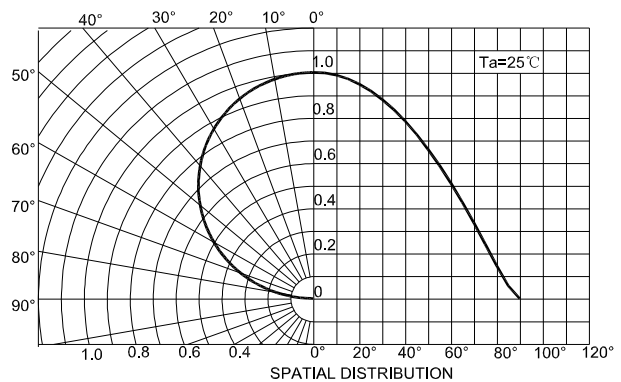

Diagram characteristics of radiation





## HL-AF-5060U32YC-3-S1-T1

### Reliability Test Items And Conditions

The reliability of products shall be satisfied with items listed below.  
Confidence level :90%  
LTPD :10%

| No. | Items                             | Ref.Standard | Test Condition                                    | Test Hours/<br>Cycles | Sample Size | Ac/Re |
|-----|-----------------------------------|--------------|---|-----------------------|-------------|-------|
| 1   | Reflow                            | JESD22-B106  | Temp:260°C max<br>T=10 sec                        | 3 times.              | 22Pcs.      | 0/1   |
| 2   | Temperature Cycle                 | JESD22-A104  | 100°C±5°C 30 min.<br>↑↓5 min<br>-40°C±5°C 30 min. | 100 Cycles            | 22Pcs.      | 0/1   |
| 3   | Thermal Shock                     | JESD22-A106  | 100°C±5°C 5 min.<br>↑↓<br>-40°C±5°C 5 min.        | 100 Cycles            | 22Pcs.      | 0/1   |
| 4   | High Temperature Storage          | JESD22-A103  | Temp:100°C±5°C                                    | 1000Hrs.              | 22Pcs.      | 0/1   |
| 5   | Low Temperature Storage           | JESD22-A119  | Temp:-40°C±5°C                                    | 1000Hrs.              | 22Pcs.      | 0/1   |
| 6   | DC Operating Life                 | JESD22-A108  | Ta=25°C±5°C<br>IF=60mA                            | 1000Hrs.              | 22Pcs.      | 0/1   |
| 7   | High Temperature<br>High Humidity | JESD22-A101  | 85°C±5°C/ 85%RH<br>IF=15mA                        | 1000Hrs.              | 22Pcs.      | 0/1   |

\*The technical information shown in the data sheets are limited to the typical characteristics and circuit examples of the referenced products. It does not constitute the warranting of industrial property nor the granting of any license.

## HL-AF-5060U32YC-3-S1-T1

### SMT Reflow Soldering Instructions

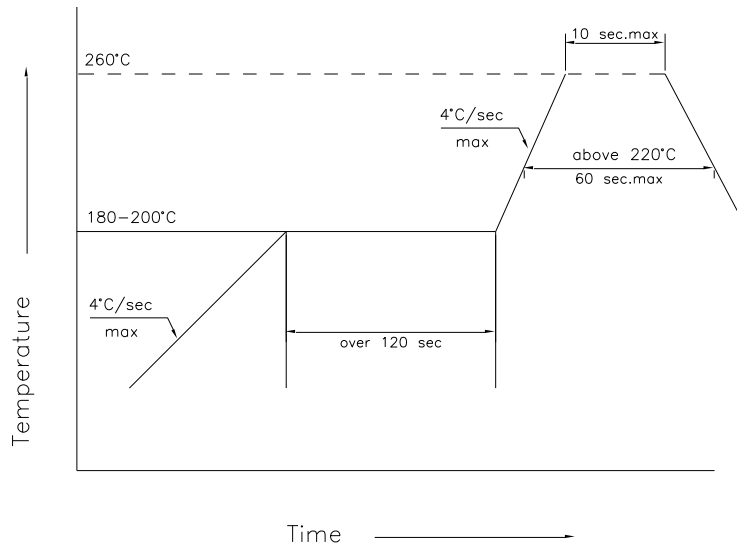

1. Reflow soldering should not be done more than two times
2. When soldering, do not put stress on the LEDs during heating

### Soldering iron

1. When hand soldering, the temperature of the iron must be less than 300°C for 3 seconds
2. The hand solder should be done only one time

### Repairing

Repair should not be done after the LEDs have been soldered. When repairing is unavoidable, a double-head soldering iron should be used (as below figure). It should be confirmed beforehand whether the characteristics of LEDs will or will not be damaged by repairing.

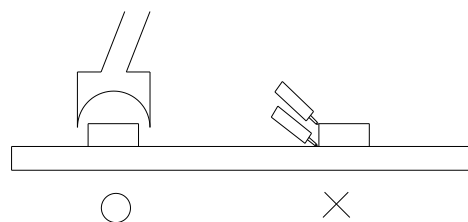



## HL-AF-5060U32YC-3-S1-T1

### Handling Precautions

Compare to epoxy encapsulant that is hard and brittle, silicone is softer and flexible. Although its characteristic significantly reduces thermal stress, it is more susceptible to damage by external mechanical force. As a result, special handling precautions need to be observed during assemble using silicone encapsulated LED products, Failure to comply might leads to damage and premature failure of the LED.

1.Handle the component along the side surface by using forceps or appropriate tools; do not directly touch or Handle the silicone lens surface, it may damage the internal circuitry.

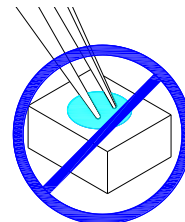
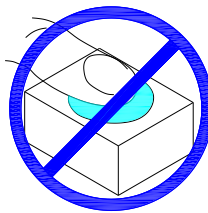
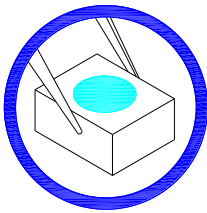

2.The outer diameter of the SMD pickup nozzle should not exceed the size of the LED to prevent air leaks. The inner diameter of the nozzle should be as large as possible. A pliable material is suggested for the nozzle tip to avoid scratching or damaging the LED surface during pickup. The dimensions of the component must be accurately programmed in the pick-and-place machine to insure precise pickup and avoid damage during production.



3.Do not stack together assembled PCBs containing LEDs. Impact may scratch the silicone lens or damage the internal circuitry

4.Not available in the situation of acidity for PH

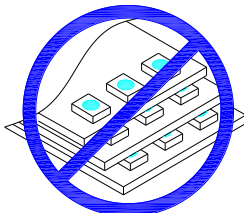

5.LED operating environment and sulfur element composition cannot be over 100PPM in the LED mating

6.When we need to use external glue for LED application products, please make sure that the external glue matches the LED packaging glue. Additionally ,as most of LED packaging glue is silica gel, and it has strong Oxygen permeability as well as strong moisture permeability; in order to prevent external material from getting into the inside of LED, which may cause the malfunction of LED, the single content of Bromine element is required to be less than 900PPM,the single content of Chlorine element is required to be less than 900PPM,the total content of Bromine element and Chlorine element in the external glue of the application products is required to be less than 1500PPM

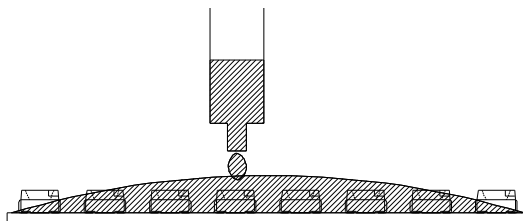

7.Other points for attention, please refer to our LED user manual.

# HL-AF-5060U32YC-3-S1-T1

## Label

IV: Luminous intensity rank  
 $\lambda$ D: Dominate Wavelength  
 VF: Forward voltage rank



**HONGLITRONIC**  
鸿利光电

RoHS

Part No: XXXXXXXXXXXXXXXXXXXXX  
 IV: VF: WD:  
 Quantity:  
 Sealing date: XXXXXXXXXXXXXXXXXXXXX



## Tape Specifications (Units : mm)

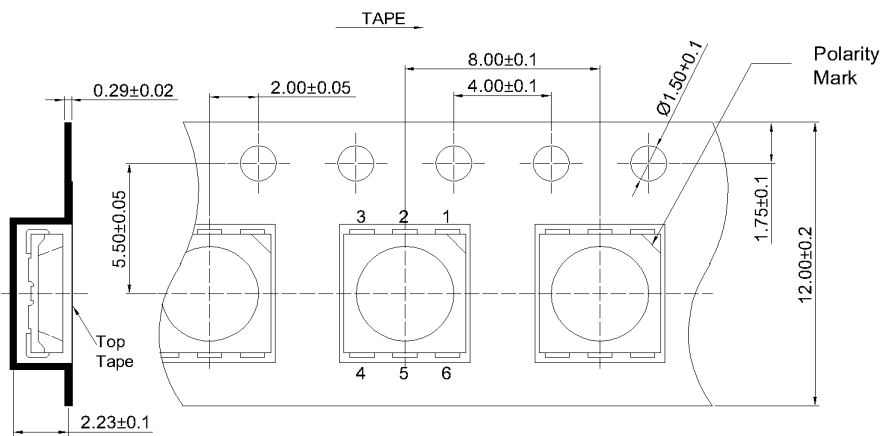

## Reel Dimensions

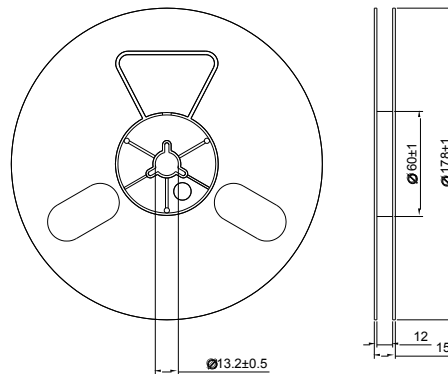

## Moisture Resistant Packaging

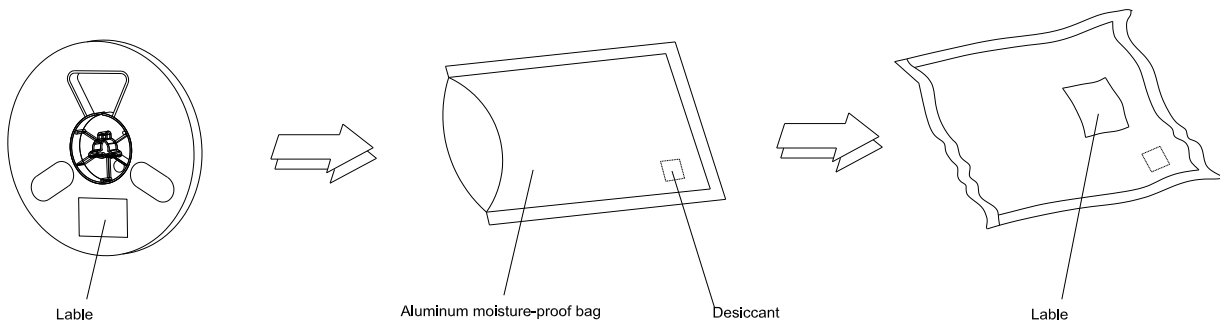

Note: The tolerances unless mentioned is  $\pm 0.1$ mm, Unit: mm