



# IGPS-R9084GP

Industrial Layer-3 12-port managed Gigabit PoE Ethernet switch with 8x10/100/1000Base-T(X) P.S.E. and 4x100/1000Base-X, SFP socket

## Features

- Supports Layer 3 routing, RIP and static routing function
- Support O-Ring (recovery time < 30ms over 250 units of connection) and MSTP(RSTP/STP compatible) for Ethernet Redundancy
- Open-Ring support the other vendor's ring technology in open architecture
- O-Chain allow multiple redundant network rings
- Support standard IEC 62439-2 MRP (Media Redundancy Protocol) function
- 8 port P.S.E. fully compliant with IEEE802.3at standard, provide up to 30 Watts per port
- Support PoE scheduled configuration and PoE auto-ping check function
- Support IEEE 1588v2 clock synchronization
- Support IPV6 new internet protocol version
- Support Modbus TCP protocol
- Support IEEE 802.3az Energy-Efficient Ethernet technology
- Provided HTTPS/SSH protocol to enhance network security
- Support SMTP client and NTP server protocol
- Support IP-based bandwidth management
- Support application-based QoS management
- Support Device Binding security function
- Support DOS/DDOS auto prevention
- IGMP v2/v3 (IGMP snooping support) for filtering multicast traffic
- Support SNMP v1/v2c/v3 & RMON & 802.1Q VLAN Network Management
- Support ACL, TACACS+ and 802.1x User Authentication for security
- Supports 9.6K Bytes Jumbo Frame
- Multiple notification for warning of unexpected event
- Supports backup unit device DBU-01 for quickly backup/restore configuration
- Web-based ,Telnet, Console (CLI), and Windows utility (Open-Vision) configuration
- Support LLDP Protocol
- Rigid IP-30 housing design
- DIN-Rail and wall mounting enabled



## Introduction

IGPS-R9084GP is Layer-3 managed redundant ring PoE Ethernet switch with 8x10/100/1000Base-T(X) P.S.E. ports and 4x100/1000Base-X SFP ports. The IGPS-R9084GP supports Layer-3 routing for better network performance on large-scale LANs into multiple subnets to support long-haul and EMI immunity communications. The hardware Layer-3 switch is optimized to transmit data as fast as Layer-2 switches. The switch support Ethernet Redundancy protocol, O-Ring (recovery time < 30ms over 250 units of connection) and MSTP (RSTP/STP compatible) can protect your mission-critical applications from network interruptions or temporary malfunctions with its fast recovery technology. IGPS-R9084GP also support Power

over Ethernet, a system to transmit electrical power up to 30 watts, along with data, to remote devices over standard twisted-pair cable in an Ethernet network. Each IGPS-R9084GP switch has 8x10/100/1000Base-T(X) P.S.E. (Power Sourcing Equipment) ports. P.S.E. is a device (switch or hub for instance) that will provide power in a PoE connection. And support wide operating temperature from -40 °C to 75 °C. IGPS-R9084GP can also be managed centralized and convenient by Open-Vision, Except the Web-based interface, Telnet and console (CLI) configuration. Therefore, the switch is one of the most reliable choice for highly-managed and Fiber Ethernet application.

- **O-Ring :** O-Ring is ORing's proprietary redundant ring technology, with recovery time of less 30 milliseconds and up to 250 nodes. The O-Ring redundant ring technology can protect mission-critical application from network interruptions or temporary malfunction with its fast recover technology.
- **Open-Ring :** Open-Ring is an enhanced redundant technology that makes ORing's switches compatible with other vendor's proprietary redundant ring technologies. It enables ORing's switches to form a single ring with other vendor's switch. In cases where the ring is setup using proprietary technology, ORing offers a compatibility service where ORing can make its switches compatible with your particular network requirements.
- **O-Chain :** O-Chain is the revolutionary network redundancy technology that provides the add-on network redundancy topology for any backbone network, O-Chain allows multiple redundant network rings of different redundancy protocols to join and function together as a larger and more robust compound network topology. O-Chain providing ease-of-use while maximizing fault-recovery swiftness, flexibility, compatibility, and cost-effectiveness in one set of network redundancy topology.
- **MRP :** Media Redundancy Protocol (MRP) is a data network protocol standardized by the IEC 62439-2. It allows rings of Ethernet switches to overcome any single failure with recovery time much faster than achievable with Spanning Tree Protocol.
- **IP-based Bandwidth Management :** The switch provide advanced IP-based bandwidth management which can limit the maximum bandwidth for each IP device. User can configure IP camera and NVR with more bandwidth and limit other device bandwidth.
- **Application-Based QoS :** The switch also support application-based QoS. Application-based QoS can set highest priority for data stream according to TCP/UDP port number.
- **Device Binding Function :** ORing special Device Binding function can only permit allowed IP address with MAC address to access the network. Hacker cannot access the IP surveillance network without permission. It can avoid hacker from stealing video privacy data and attacking IP camera, NVR and controllers.
- **Advanced DOS/DDOS Auto Prevention :** The switch also provided advanced DOS/DDOS auto prevention. If there is any IP flow become big in short time, the switch will lock the source IP address for certain time to prevent the attack. It's hardware based prevention so it can prevent DOS/DDOS attack immediately and completely.
- **IEEE 1588 Technology :** The IEEE 1588 technology can fulfill precision time synchronization requirements for protection and control applications.
- **Modbus TCP :** This is a Modbus variant used for communications over TCP/IP networks.
- **IEEE 802.3az Energy-Efficient Ethernet :** This is a set of enhancements to the twisted-pair and backplane Ethernet family of networking standards that will allow for less power consumption during periods of low data activity. The intention was to reduce power consumption by 50% or more.

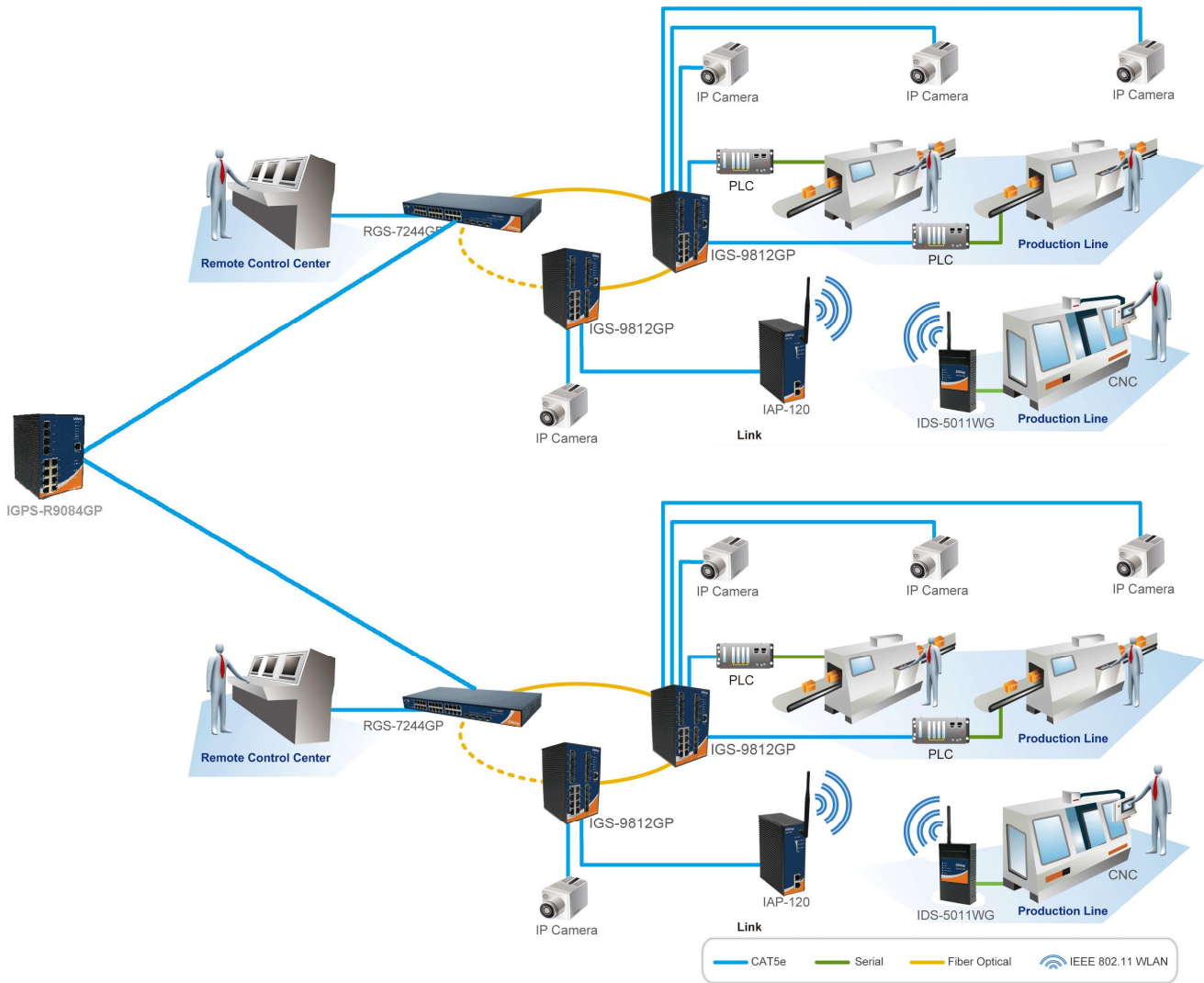

## Open-Vision

ORing's switches are intelligent switches. Different from other traditional redundant switches, ORing provides a set of Windows utility (Open-Vision) for user to manage and monitor all of industrial Ethernet switches on the industrial network.

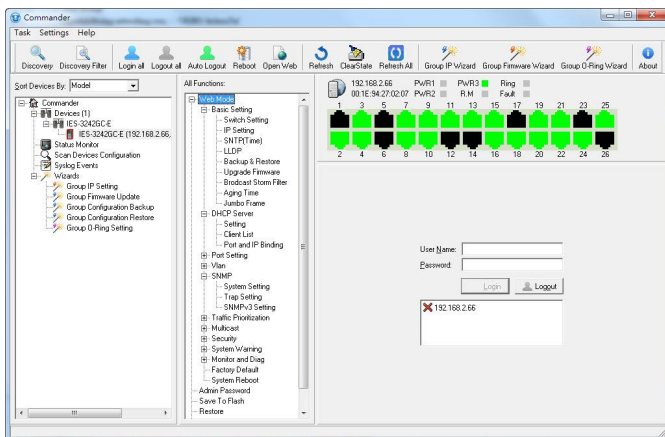

Commander

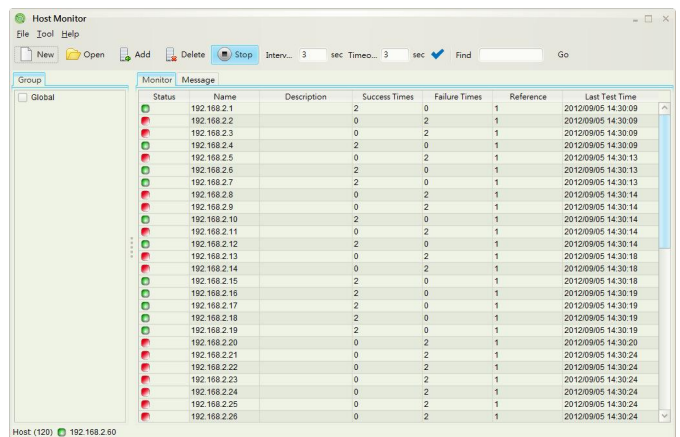

Host Monitor

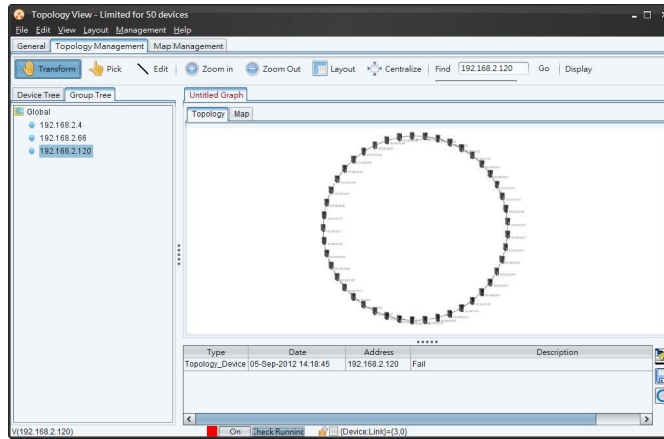

Topology View

## Dimension

Unit =mm

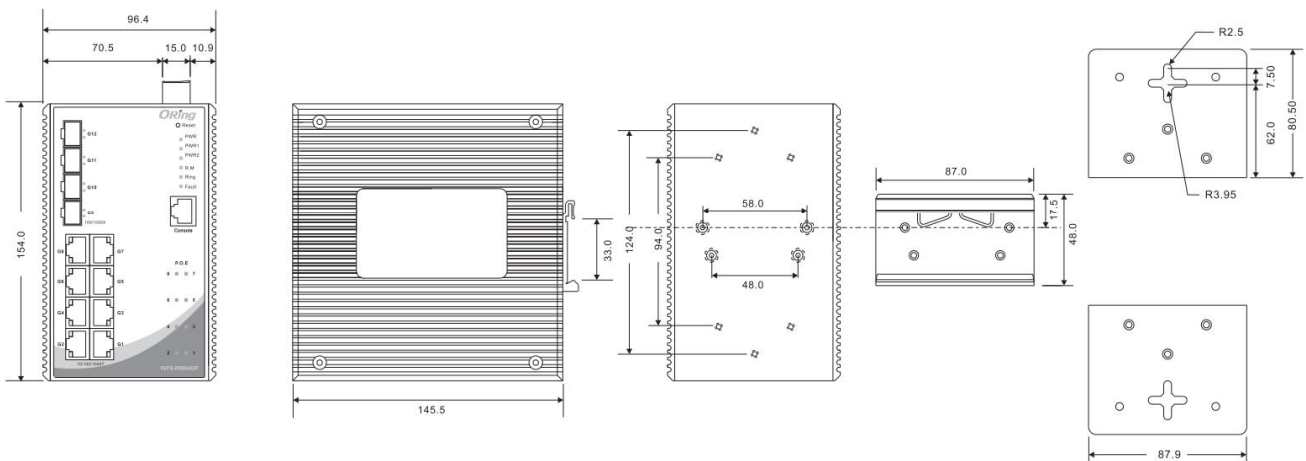

## PoE Pin Definition

- 10/100Base-T(X) P.S.E. RJ-45 port

RJ-45 Pin Definition	
Pin No.	Description
#1	TD+ with PoE Power input +
#2	TD- with PoE Power input +
#3	RD+ with PoE Power input -
#6	RD- with PoE Power input -

- 1000Base-T P.S.E. RJ-45 port

RJ-45 Pin Definition	
Pin No.	Description
#1	BI_DA+ with PoE Power input +

#2	BI_DA- with PoE Power input +
#3	BI_DB+ with PoE Power input -
#4	BI_DC+
#5	BI_DC-
#6	BI_DB- with PoE Power input -
#7	BI_DD+
#8	BI_DD-

## Specifications

ORing Switch Model	IGPS-R9084GP
<b>Physical Ports</b>	
10/100/1000Base-T(X) with P.S.E. Ports in RJ45 Auto MDI/MDIX	8
100/1000Base-X with SFP port	4
<b>Technology</b>	
Ethernet Standards	IEEE 802.3 for 10Base-T IEEE 802.3u for 100Base-TX and 100Base-FX IEEE 802.3ab for 1000Base-T IEEE 802.z for 1000Base-X IEEE 802.3x for Flow control IEEE 802.3ad for LACP (Link Aggregation Control Protocol ) IEEE 802.1p for COS (Class of Service) IEEE 802.1Q for VLAN Tagging IEEE 802.1w for RSTP (Rapid Spanning Tree Protocol) IEEE 802.1s for MSTP (Multiple Spanning Tree Protocol) IEEE 802.1x for Authentication IEEE 802.1AB for LLDP (Link Layer Discovery Protocol) IEEE 802.3at PoE specification (up to 30 Watts per port for P.S.E.)
MAC Table	8k
Packet Buffer	32Mbits
Flash Memory	128Mbits
DRAM Size	1Gbits
Up to 9.6K Bytes	Up to 9.6K Bytes
Priority Queues	8
Processing	Store-and-Forward
Switch Properties	Switching latency: 7 us Switching bandwidth: 24Gbps Max. Number of Available VLANs: 256 IGMP multicast groups: 128 for each VLAN Port rate limiting: User Define
Security Features	Device Binding security feature Enable/disable ports, MAC based port security Port based network access control (802.1x) Single 802.1x and Multiple 802.1x MAC-based authentication QoS assignment Guest VLAN MAC address limit TACACS+ VLAN (802.1Q ) to segregate and secure network traffic Radius centralized password management SNMPv3 encrypted authentication and access security Web and CLI authentication and authorization Authorization (15 levels) IP source guard

	Https / SSH enhance network security
Software Features	<p>Hardware routing, RIP and static routing</p> <p>IEEE 1588v2 clock synchronization</p> <p>IEEE 802.1D Bridge, auto MAC address learning/aging and MAC address (static)</p> <p>Multiple Registration Protocol (MRP)</p> <p>RSTP/MSTP (IEEE 802.1w/s)</p> <p>Redundant Ring (O-Ring) with recovery time less than 30ms over 250 units</p> <p>TOS/Diffserv supported</p> <p>Quality of Service (802.1p) for real-time traffic</p> <p>VLAN (802.1Q) with VLAN tagging</p> <p>Voice VLAN</p> <p>IGMP v2/v3 Snooping</p> <p>IP-based bandwidth management</p> <p>Application-based QoS management</p> <p>DOS/DDOS auto prevention</p> <p>Port configuration, status, statistics, monitoring, security</p> <p>DHCP Server/Client/snooping</p> <p>DHCP Relay</p> <p>Modbus TCP</p> <p>DNS client proxy</p> <p>ARP inspection</p> <p>SMTP Client</p> <p>NTP Server</p>
Network Redundancy	<p>O-Ring</p> <p>Open-Ring</p> <p>O-Chain</p> <p>Fast Recovery</p> <p>MRP</p> <p>MSTP (RSTP/STP compatible)</p>
RS-232 Serial Console Port	RS-232 in RJ45 connector with console cable. 115200bps, 8, N, 1
<b>LED indicators</b>	
Power Indicator (PWR)	Green : Power LED x 3
Ring Master Indicator (R.M.)	Green : Indicates that the system is operating in O-Ring Master mode
O-Ring Indicator (Ring)	Green : Indicates that the system operating in O-Ring mode Green Blinking : Indicates that the Ring is broken.
Fault Indicator (Fault)	Amber : Indicate unexpected event occurred
10/100/1000Base-T(X) RJ45 Port Indicator	Dual color LED : Green for 1000Mbps Link/Act indicator. Amber for 10/100Mbps Link/Act indicator
100/1000Base-X SFP Port Indicator	Green for port Link/Act.
PoE Indicator	Green : PoE enabled LED x 8
<b>Fault contact</b>	
Relay	Relay output to carry capacity of 1A at 24VDC
<b>Power</b>	
Redundant Input power	Dual DC inputs. 50~57VDC on 6-pin terminal block
Power consumption (Typ.)	19 Watts (PoE output not included)
Overload current protection	Present
Reverse Polarity Protection	Not Present
<b>Physical Characteristic</b>	
Enclosure	IP-30
Dimension (W x D x H)	96.4 x 145.5 x 154 mm (3.8 x 5.73 x 6.06 inch)
Weight (g)	1560 g
<b>Environmental</b>	
Storage Temperature	-40 to 85°C (-40 to 185°F)
Operating Temperature	-40 to 75°C (-40 to 167°F)
Operating Humidity	5% to 95% Non-condensing
<b>Regulatory approvals</b>	
EMI	FCC Part 15, CISPR (EN55022) class A

EMS	EN61000-4-2 (ESD), EN61000-4-3 (RS), EN61000-4-4 (EFT), EN61000-4-5 (Surge), EN61000-4-6 (CS), EN61000-4-8, EN61000-4-11
Shock	IEC60068-2-27
Free Fall	IEC60068-2-32
Vibration	IEC60068-2-6
Safety	EN60950-1
Warranty	5 years

## Ordering Information

IGPS-R9AABCC

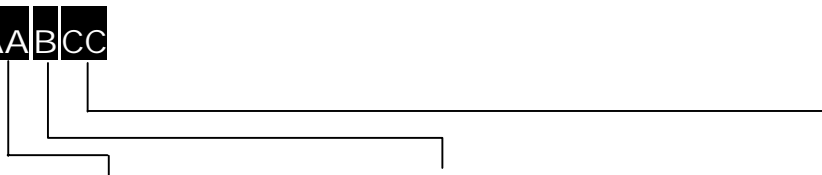

Code	10/100/1000Base-T(X) P.S.E.	100/1000Base-X	SFP	Port	Additional Port Type
Definition	Port Number	Number			
Option	- 08: 8 ports	- 4: 4 ports			-GP: Gigabit SFP ports

Available Model	Model Name	Description
	<b>IGPS-R9084GP</b>	Industrial Layer-3 12-port managed Gigabit PoE Ethernet switch with 8x10/100/1000Base-T(X) P.S.E. and 4x100/1000Base-X, SFP socket

## Packing List

- IGPS-R9084GP x 1
- DIN-Rail Kit x 1
- ORing Tool CD x 1
- Wall-mount Kit x 2
- Quick Installation Guide x 1
- Console Cable x 1

## Optional Accessories

- Open-Vision M500 : Powerful Network Management Windows Utility Suit, 500 IP devices
- SFP100 series : 100Mbps SFP optical transceiver
- SFP 1G series : 1Gbps SFP optical transceiver