

ALTW
CONFIDENTIAL
2015-09-29
R&D DEPT.

REV.	ECN NO.	DATE	SIGN	DESCRIPTION

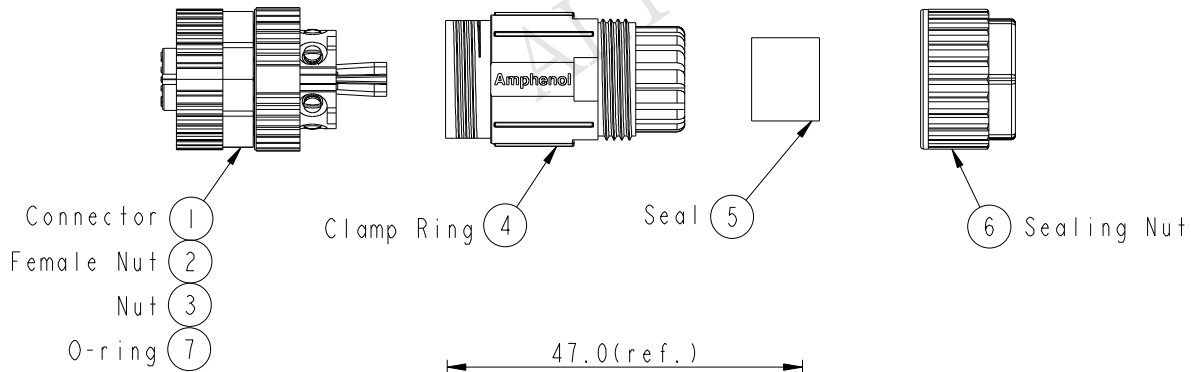

ALTW
DCC. DEPT.
CONFIDENTIAL
2015.10.28
ISSUED

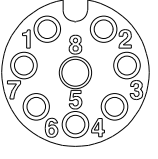
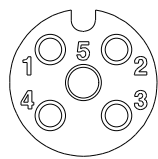
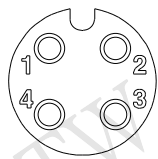
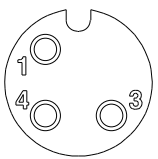
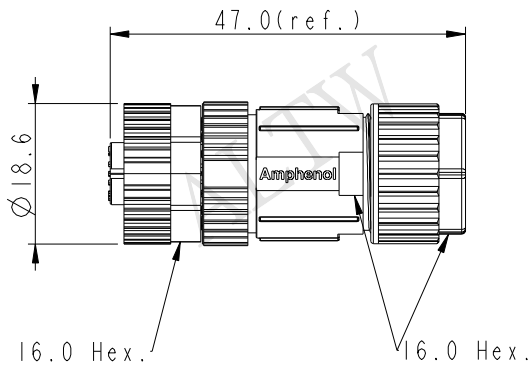

Pin Assignments Front View

UNIT:mm		
TOLERANCE		
±0.5mm		

TITLE M12 A-code Plastic Assy F Conn. F Pin			
SCALE 1:1	SIZE A4	SHEET 1 OF 2	
REV. A	WC-REV. A.3	QC: Inspection item	

Amphenol LTW
安費諾亮泰企業股份有限公司

ITEM NO	DRAWN BY Mila	DATE 2015-09-29
DWG NO MSAP-XXBFFB-SL7001	CHECKED BY Cary	DATE 2015-09-29
CUSTOMER ALTW	APPROVED BY Jerry	DATE 2015-09-29

THIS DOCUMENT IS SUBJECT TO CHANGE WITHOUT NOTICE. IT IS CONFIDENTIAL AND A PROPERTY OF Amphenol LTW. DISCLOSURE TO THIRD PARTY HAS TO BE AUTHORIZED BY Amphenol LTW.

THIS DOCUMENT IS SUBJECT TO CHANGE WITHOUT NOTICE. IT IS CONFIDENTIAL AND A PROPERTY OF AMPHENOL LTW. DISCLOSURE TO THIRD PARTY HAS TO BE AUTHORIZED BY AMPHENOL LTW.

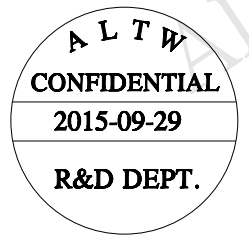
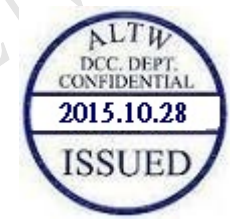
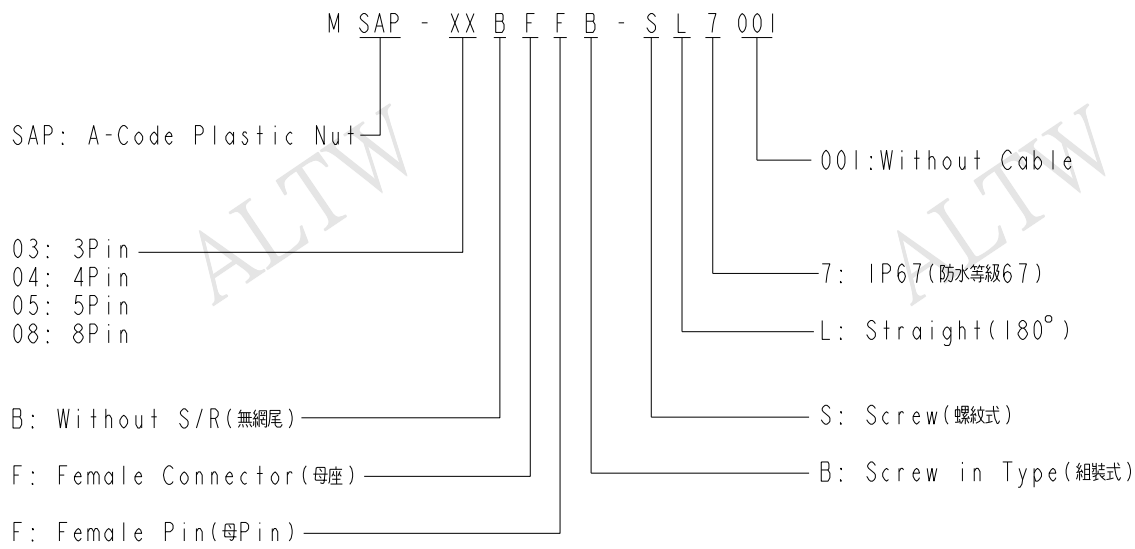

- Note:
- * Important Dimension To Check.
 - * Waterproof Rate: IP67
 - * Housing: Nylon, Black
 - * Female Pin: Copper Alloy, Gold Plated
 - * Female Nut: PBT+PC, Black
 - * Nut: PBT+PC, Black
 - * O-Ring: Silicon, Grey
 - * Clamp Ring: Nylon, Black
 - * Sealing Nut: PBT+PC, Black
 - * Seal: Silicon, Grey
 - * Seal For Cable OD: $\varnothing 4.0\text{mm} \sim \varnothing 8.0\text{mm}$
 - * Screws for Wire connection recommended
tightening torque: 0.61~0.84 kgf.cm / 0.059~0.082 N.m
 - * Applicable Wire gauge (Stranded wire cross section)
0.14mm² (26AWG) ~ 0.82mm² (18AWG)
 - * Mating Recommended tightening torque:
3~4 kgf.cm / 0.29~0.39 N.m
 - * Sealing-Nut Recommended tightening torque:
4~6 kgf.cm / 0.39~0.59 N.m
 - * Detailed applicable wire specifications may vary
depending on the actual wire construction.

A	UNIT:mm		TITLE M12 A-code Plastic Assy F Conn. F Pin		ITEM NO		DRAWN BY Mila	DATE 2015-09-29
	TOLERANCE $\pm 0.5\text{mm}$		SCALE 1:1	SIZE A4	SHEET 2 OF 2	DWG NO MSAP-XXBFFB-SL7001	CHECKED BY Cary	DATE 2015-09-29
			REV. A	WC-REV. A.3	: Inspection item	CUSTOMER ALTW	APPROVED BY Jerry	DATE 2015-09-29
				Amphenol LTW 安費諾亮泰企業股份有限公司				8 FMM10702-01-02A1